

## August 1998

The information in this document is subject to change without notice and should not be construed as a commitment by the manufacturer.

The manufacturer assumes no responsibility for any errors that might appear in this document.

The software described in this document is furnished under a license and may be used or copied only in accordance with the terms of such license. No responsibility is assumed for the use or reliability of software or equipment that is not supplied by the manufacturer or its affiliated companies.

**Restricted Rights:** Use, duplication, or disclosure by the U.S. Government is subject to restrictions as set forth in subparagraph (c) (1) (ii) of the Rights in Technical Data and Computer Software clause at DFARS 252.227-7013.

© Compal Electronics 1998. All Rights Reserved.

Pentium is a registered trademark of Intel Corporation.

MS-DOS and Windows are registered trademarks of Microsoft Corporation.

Sound Blaster is a registered trademark of Creative Labs Corporation.

Macrovision is a registered trademark of Macrovision Corporation.

Dolby is a registered trademark of Dolby Laboratories Inc.

ATI is a registered trademark of ATI Technology Inc.

ESS and Maestro are registered trademarks of ESS Technology Inc.

All other trademarks and registered trademarks are the property of their respective holders.

## **The FCC wants you to know...**

This equipment has been tested and found to comply with the limits for a Class B digital device, pursuant to Part 15 of the FCC rules. These limits are designed to provide reasonable protection against harmful interference in a residential installation.

Any changes or modifications made to this equipment may void the user's authority to operate this equipment.

This equipment generates, uses, and can radiate radio frequency energy and, if not installed and used in accordance with the instructions, may cause harmful interference to radio communications. However, there is no guarantee that interference will not occur in a particular installation. If this equipment does cause harmful interference to radio or television reception, which can be determined by turning the equipment off and on, the user is encouraged to try to correct the interference by one or more of the following measures:

- Reorient or relocate the receiving antenna.
- Increase the separation between the equipment and receiver.
- Connect the equipment into an outlet on a circuit different from that to which the receiver is connected.
- Consult the dealer or an experienced radio/TV technician for help.
- All external cables connecting to this basic unit must be shielded. For cables connecting to PCMCIA cards, see the option manual or installation instructions.

## **PART 68 OF NOTICE**

This equipment with Part 68 of the FCC Rules. On the bottom of the computer is a label that contains, among other information, the FCC Registration Number and Ringer Equivalence Number (REN) for this equipment. You must, upon request, provide this information to your telephone company.

FCC Part 68 Registration Number:

REN:

The REN is useful to determine the quantity of devices you may connect to your telephone and still have all of those devices ring when your number is called. In most, but not all areas, the sum of the REN's of all devices should not exceed five (5.0). To be certain of the number of devices you may connect to your line, as determined by the REN, you should call your local telephone company to determine the maximum REN for your calling area.

If your modem causes harm to the telephone network, the local Telephone Company may discontinue your service temporarily. If possible, they will notify you in advance. But if advanced notice isn't practical, you will be notified as soon as possible. You will be informed of your right to file a complaint with the FCC.

Your telephone company may make changes in its facilities, equipment, operations, or procedures that could affect the proper functioning of your equipment. If they do, you will be notified in advance to give you an opportunity to maintain uninterrupted telephone service.

## **CANADIAN DOC NOTICE**

This digital apparatus does not exceed the Class B limits for radio noise emissions from digital apparatus as set out in the Radio Interference Regulation of the Canadian Department of Communications.

"Le présent appareil numérique n'émet pas de bruits radioélectriques dépassant les limites applicables aux appareils numériques de la class B prescrites dans le Règlement sur le brouillage radioélectrique édicté par le ministère des Communications du Canada"

## **Macrovision License of Notice**

This product incorporates copyright protection technology that is protected by method claims of certain U.S. patents and other intellectual rights owned by Macrovision Corporation, and other rights owners. Use of this copyright protection technology must be authorized by Macrovision Corporation, and is intended for home and other limited viewing uses only unless otherwise authorized by Macrovision Corporation. Reverse engineering or disassembly is prohibited.

## **Dolby License of Notice**

Manufactured under license from Dolby Laboratories. Confidential Unpublished Works @ 1992 – 1997 by Dolby Laboratories Inc. All rights reserved.

# Table of Contents

<b>Chapter 1.....</b>	<b>1</b>
<i>Introducing the Notebook.....</i>	<i>1</i>
Features and Controls.....	2
Optional Devices.....	6
Unpacking & Checking the Equipment.....	7
Identifying Parts of the Notebook.....	8
Installation and Initial Setup.....	13
<b>Chapter 2 .....</b>	<b>19</b>
<i>The BIOS Setup Program.....</i>	<i>19</i>
Introduction.....	19
Navigating through the BIOS Setup Program.....	20
The Main Menu.....	24
The System Devices Menu.....	26
The Security Menu.....	32
The Power Menu.....	34
The Boot Menu.....	38
The Exit Menu.....	39
<b>Chapter 3.....</b>	<b>43</b>
<i>Operation.....</i>	<i>43</i>
Introduction.....	43
Video Display Controls.....	43
Some Important Keys on the Keyboard.....	44
Cursor Control Keys and Editing Keys.....	45
The Function Keys.....	47
Embedded Numeric Keypad.....	47
Hot Keys for System Control.....	48
The System Status Window .....	48
LED Status Indicators.....	51
Battery Charging Control.....	53
Using the Touch Pad.....	53
The FIR Module.....	55

Multimedia Sound System.....	56
Audio Volume Control.....	57
<b>Chapter 4.....</b>	<b>59</b>
<i>Peripherals.....</i>	<i>59</i>
Additional Equipment.....	60
Connecting Peripheral Devices.....	62
<b>Chapter 5.....</b>	<b>69</b>
<i>The Power System.....</i>	<i>69</i>
The AC Adapter.....	70
The Battery Power System.....	70
Removing the Battery Pack.....	71
Inserting the Battery Pack.....	72
Automatic Battery Pack Charging Function.....	72
AC Power Connection.....	73
Using Battery Power.....	75
Battery Life Status.....	75
Low Battery Activity.....	75
Small Battery for Real Time Clock.....	75
Power Management Habits.....	75
Power Management Modes.....	76
Controllable Features.....	80
Smart CPU Mode.....	80
Cover Lid Switch.....	81
Reactivating From Power Saving Modes.....	81
Power Management Summary.....	81
The APM Interface.....	82
<b>Chapter 6.....</b>	<b>84</b>
<i>Expansion Options.....</i>	<i>84</i>
System Memory Expansion.....	84
Installing Memory Cards.....	85
Installing and Removing Modules.....	86
Optional Modules.....	88
Removing and Installing HDD Modules.....	89
The I/O Port Replicator.....	91

The AC Adapter and Peripherals Connection.....	92
The Notebook to I/O Port Replicator Connection.....	92
Removing the Notebook from the I/O Port Replicator.....	94
I/O Replicator Specifications.....	94
<b>Chapter 7.....</b>	<b>96</b>
<i>Caring for your Notebook.....</i>	<i>96</i>
General Maintenance.....	96
Cleaning The Computer.....	97
Safety Precautions.....	99
<b>Appendix A.....</b>	<b>102</b>
<i>Troubleshooting.....</i>	<i>102</i>
An Approach to Troubleshooting.....	103
I/O Connections.....	105
<b>Appendix B.....</b>	<b>106</b>
<i>Specifications.....</i>	<i>106</i>

## Abbreviations

<b>Abbreviation</b>	<b>Meaning</b>
ACPI	<i>Advanced Configuration and Power Interface</i>
APM	<i>Advanced Power Management (This Notebook supports APM 1.2)</i>
BIOS	<i>Basic Input/Output System</i>
CMOS	<i>Complementary Metal Oxide Semi-conductor</i>
DIMM	<i>Dual In-line Memory Module</i>
DMA	<i>Direct Memory Access</i>
DRAM	<i>Dynamic Random Access Memory</i>
DVD	<i>Digital Versatile Disc</i>
EDO RAM	<i>Extended Data Out Random Access Memory</i>
IDE	<i>Integrated Drive Electronics (internal hard disk drive interface)</i>
FIR	<i>Fast Infrared</i>
GB	<i>Gigabyte (1GB = 1,073,741,824 bytes or 1,024MB)</i>
ISA	<i>Industry Standard Architecture</i>
KB	<i>Kilobyte (1KB = 1,024 bytes)</i>
LCD	<i>Liquid Crystal Display</i>
MB	<i>Megabyte (1MB = 1,048,576 bytes or 1,024KB)</i>
MIDI	<i>Musical Instrument Digital Interface</i>
MPEG	<i>Motion Picture Experts Group</i>
MS-DOS	<i>Microsoft Disk Operating System</i>
PCI	<i>Peripheral Component Interconnect</i>
PCMCIA	<i>Personal Computer Memory Card International Association</i>
POST	<i>Power On Self-Test</i>
PnP	<i>Plug and Play</i>
RAM	<i>Random Access Memory</i>
RAMDAC	<i>Random Access Memory Digital to Analog Converter</i>
ROM	<i>Read Only Memory</i>
VGA	<i>Video Graphics Array</i>
SVGA	<i>Super Video Graphics Array</i>
UART	<i>Universal Asynchronous Receiver Transmitter</i>
XGA	<i>Extended Graphics Array</i>
YUV	<i>The video native signal format</i>

## ABOUT THIS GUIDE

This guide describes how to operate, configure, and troubleshoot the Notebook computer. With this easy to use guide, you will be able to quickly familiarize yourself with all aspects of the Notebook computer.

## Organization

This guide contains the following:

**Chapter 1:** *Introducing the Notebook* - This chapter identifies the external components of the Notebook and provides a quick reference to the Notebook functions. It also shows you how to get the Notebook up and running for the first time and covers creating a comfortable working environment.

**Chapter 2:** *The BIOS Setup Program* - This section introduces the Setup program, discusses how to move around in the Setup program, as well as how to specify and save your new settings. A detailed list of the optional settings among the different menus is also provided.

**Chapter 3:** *Operation* - This chapter provides information pertaining to the Video Display Controls used to adjust the LCD screen's appearance. Also included in this chapter is a brief overview of the keyboard, the LCD Status Display icons, the Touch Pad, the FIR module, and a description of the audio features of the Notebook.

**Chapter 4:** *Peripheral Devices* - This chapter overviews the peripherals that can be connected to the Notebook, the necessary requirements for using these peripherals with your Notebook and instructions on how to connect these devices to your Notebook.

**Chapter 5:** *Power System* - This chapter contains information on the Notebook's power system, including the AC Adapter, the battery system, recharging the battery, and tips for conserving battery power. Also included is a detailed description of power management.

**Chapter 6:** *Expansion Options* - This chapter describes the optional equipment that can be added to the basic Notebook system. Also covered in this chapter is step by step information on installing and removing the optional modules that can be inserted in the Notebook.

**Chapter 7: *Caring for Your Notebook*** - This chapter covers some of the basic maintenance procedures you may want to familiarize yourself with. It introduces proper methods of cleaning the case, the screen, the FDD drive, as well as some helpful tips on handling diskettes.

**Appendix A: *Troubleshooting*** - In a question and answer format, this section provides you with solutions to possible problems that may arise.

**Appendix B: *Technical Specifications*** - This appendix lists your Notebook computer's operating specifications.

## Special Notices

Three kinds of special notices are used in this guide to emphasize specific information.

 **Note!** Provides additional information.

 **Warning!** Indicates the presence of a hazard that can cause damage to the Notebook or other equipment.

 **Important!** Alerts you to a condition that may hamper the performance of the Notebook.

# CHAPTER 1

## INTRODUCING THE NOTEBOOK

Your new Notebook features the most innovative advances in portable computing technology. It combines state-of-the-art ergonomics with sophisticated architecture to provide you with a personal computer that is compact, powerful, and easy to use.

The modular design of the Notebook provides maximum expandability without compromising portability. The high-performance Pentium® II CPU and PCI hard drive provide you with the extra processing power needed to handle complex graphics and large sound files. Two PCMCIA slots give you the ability to use standard PCMCIA cards, such as a LAN adapter or memory cards. The Notebook has a unique space-saving Combo Module, located on the front panel of the Notebook for easy access. The Combo Module combines a CD-ROM and an FDD in a single case providing access to a greater variety of graphics and multimedia software.

This User's Guide describes all the features of the Notebook in an easy-to-read yet thorough manner. The primary goals of this chapter are to identify the Notebook's external components and to provide a quick reference of the Notebook functions for experienced computer users.

## Features and Controls

---

This section provides an overview of the Notebook's features. For more detailed information see the Specifications section in Appendix B. Your Notebook includes the following features:

### **CPU**

The microprocessor (CPU) is the heart and brain of the computer. It performs all the computing functions and orchestrates the actions of the system. This Notebook was designed with a Pentium® II CPU.

CPU upgrades are possible. Changing a Pentium® II CPU requires much skill and knowledge. If you are not absolutely sure that you have the capability to change a Pentium® II CPU by yourself, let your Notebook dealer do it for you. Removing the CPU in an improper way may damage the Notebook's main board, resulting in costly repairs.

Your Notebook supports the state-of-the-art Intel Mobile Deschutes CPU with Intel or 440BX system logic. The Pentium family CPU operates at 3.3 volts or less, and therefore consumes less energy and generates less heat than 5-volt CPUs.

### **Combo Module (FDD/CD-ROM)**

The Notebook Combo Module combines a 24X CD-ROM and an FDD (Floppy Disk Drive) in a single unique space-saving module. The FDD can use either 720KB double density or 1.44MB high-density 3.5-inch floppy diskettes. Floppy diskettes are useful for making backups of your program diskettes and data files.

The FDD/CD-ROM module can be removed and an FDD/DVD module, LS-120 drive, or second battery pack can be inserted in this bay. For information on swapping modules, see the *Installing and Removing Modules* section in Chapter 6.

### **Hard Drive**

The Notebook comes with a 2.5"/12.7mm or 17mm high hard disk (up to 8GB) installed. An Intel Mobile HDD interface with PCI Bus Master IDE and support for Ultra 33 synchronous DMA (ATA-33) and PIO Mode 4 timing. Like the FDD, the hard drive is also of modular design. It can be easily removed and replaced with a second hard drive for the purpose of data backup or expansion. Consult your dealer to find out the capacity of the hard drive installed in your Notebook.

### **LCD VGA Display**

Your Notebook's VGA display is a 13.3" or a 14.1" Color TFT LCD with a 1024 x 768 XGA resolution back-light display.

## **VGA Graphics Accelerator and Video Subsystem**

This Notebook is equipped with an ATI 3D Rage LT PRO VGA AGP controller chip offering the following features:

- Supports AGP Bus (a clock-doubling technique boosts speed to 133MHz)
- Supports simultaneous LCD and CRT displays, and simultaneous LCD and TV displays
- Support for 4MB and 8MB frame buffers, and integrated 230MHz DAC
- Superior 2D performance with support for 100MHz SGRAM
- Supports Non-interlaced CRT monitors with resolutions of up to 1600 x 1200 at 24-bit color with 8MB SGRAM
- Supports Advanced Power Management features which minimize power consumption during:
  - Normal operation
  - Standby mode
  - Suspend mode
  - VESA DDCII/DPMS
- Graphics Accelerator for Windows Applications
- 3.3V/5V panel Interface support
- True-color and Hi-color display capabilities (for TFT LCD panels only)
  - 16 bits per pixel with a resolution of up to 640 x 480
  - 8 bits per pixel with a resolution of up to 1024 x 768
- Video acceleration with arbitrary scaling (horizontal and vertical interpolation and YUV to RGB conversion)
- Zoom Video Capture and MPEG support with dual ZV port video inputs

## **87/88-key Enhanced Keyboard**

The Notebook's keyboard has a standard QWERTY layout with the addition of special function keys. It is available in either 87 or 88-key layouts that emulate a full-size desktop 101/102-key keyboard. The keyboard features an embedded numeric keypad for number intensive data entry, with independent [Page Down], [Page Up], [Home], and [End] keys.

## **Windows 95/98 Enhanced Keyboard**

The keyboard supports Windows 95/98 by incorporating two Windows specific keys. With these keys you will be able to access and take advantage of many of the time-saving features offered by Windows 95/98.

## **The Touch Pad**

The Notebook features a Touch Pad pointing device with two buttons. This pressure-sensitive pointing device allows you to move the cursor around the screen and make selections just as one would with a conventional mouse. A unique function called double tapping allows you to make selections within a software program or execute software applications without having to remove your hands from the touch-type position. Please see the *Touch Pad* section in Chapter 3 for more information on the operation of the Notebook's pointing device.

## **Connectors**

The Notebook has a number of connector (Input/Output) ports for attaching peripherals to the computer, including the following:

- A 6-pin connector for a full-size keyboard or a PS/2 mouse
- Three audio jacks used for External Mic (Mic-in), Headphone-out and Line-in
- A 15-pin CRT (monitor) port
- A standard 9-pin serial port (16550 compatible) supports a variety of serial devices such as a mouse or modem.
- A 25-pin parallel port that is most commonly used to connect a printer or Pocket LAN to the computer. The parallel port supports both EPP and ECP capabilities.
- A 240-pin connector for the Notebook's Docking Station supports 32-bit PCI bus, a PS/2 port, an AT-keyboard, 1S1P, CRT, two USB ports, and three audio ports. This connector supports hot docking and PC97/98 requirements.
- Two ACPI-compliant PCMCIA expansion sockets provide an interface for two Type II cards, or one Type III card. PC cards accommodate a number of expansion options, including memory cards, modems, hard disks, and network adapters.
- One 2-pin connector for an AC Adapter power jack
- Built-in IrDA FIR (Fast Infrared) transmitter/receivers for wireless communications
- One built-in microphone
- Two built-in speakers
- One 4-pin Universal Serial Bus (USB) connector
- One TV-Out (S-type) port
- RJ-11 Modem port (optional)
- PCI Bus connector MPEGII card (optional)

## **PCMCIA Sockets**

An ACPI-compliant PCMCIA R2.0 host adapter supports one type III PCMCIA card or two type II PCMCIA cards. The PCMCIA sockets support hot insertion and removal and can accommodate SRAM, OTPROM, FLASHROM and Mask ROM memory cards of up to 64MB, Modem/LAN cards and 10.5mm removable HDD. The host adapter also supports Zoom Video mode.

## **Battery and AC Power System**

To power the Notebook, you can use an AC Adapter or the rechargeable battery pack module. The system will automatically recharge the battery pack in the Notebook by using the AC Adapter. For information on recharging the battery while simultaneously using the Notebook, see the section in this chapter on installation and initial setup. By using the power management features described in Chapter 5, the Notebook can operate on battery power for approximately 3 hours. The battery pack takes approximately 2 hours to recharge when the computer is turned off. It takes 3 hours to recharge when the computer is in use. For extended battery-powered operation, additional battery modules may be purchased.

## **Upgradable Memory**

The Notebook is equipped with three SODIMM connectors, allowing for a maximum of 384MB of system memory to be installed, by installing one, two or three, 32MB, 64MB or 128MB 3.3V SDRAM 144-pin SO-DIMM memory modules. Refer to the *System Memory Expansion* and *Installing Memory Cards* sections in Chapter 6 for detailed information on upgrading system memory. After reviewing the appropriate sections, if you are not completely confident that you have the skill to install memory modules by yourself, please consult your Notebook dealer or technician.

## **Built-in Level 2 Cache RAM**

The Notebook provides 512KB L2 Cache RAM that will enhance the system performance, especially in the Windows environment.

## **Keyboard Controls**

The Notebook provides a host of hot key features that are a permanent part of the computer's operation. Some affect the LCD video display, while others control the sound volume. A complete list of the Notebook's hot key functions is provided in Chapter 3.

## **Power Management**

The Notebook features sophisticated power management built into the BIOS Setup program. These features are designed to conserve power and extend the life of the battery between charges.

## **FIR Port**

For convenience, the Notebook features an FIR Port (on the rear panel) that allows wireless, serial communication between the Notebook and other FIR equipped devices such as a printer or another computer. The FIR Port allows both the sending and receiving of data.

## **Audio Features**

The Notebook's audio features include:

- ESS Maestro-2 PCI Audio Accelerator (Sound Blaster Pro™ and Windows Sound System™ compatible)
- A sophisticated on-board 16-bit stereo FM sound generator featuring enhanced stereo and full-duplex playback and record with internal playback and record buffer
- 64-Voice Wavetable Synthesizer
- Secondary CODEC Interface
- AC-3 Speaker Virtualization
- Two integrated speakers and an internal microphone
- Stereo inputs for Line-in, CD-ROM and music synthesis and a mono input for the microphone
- Enhanced Digital Game Port
- Software/Hardware Master Volume Control
- Programmable Power Management
- 5-channel mixer with controls for input and output
- HRTF 3-D Positional Audio under DirectX 5.0
- A 20 Voice FM sound generator capable of simultaneous voicing of 18 melody sounds and 4 operator-voices via software control
- MIDI serial port compatible with MPU401 UART mode
- I<sup>2</sup>S interface to internal stereo D/A for external ZV port or MPEG audio
- Full PnP support
- Complies with Microsoft ACPI 1.0 and PPMI 1.0 (DO-D3)

## **Optional Devices**

---

There are several optional products you can purchase to further enhance the utility and versatility of your Notebook computer.

- HDD Module
- Combo Module: FDD/CD-ROM or FDD/DVD

- LS-120 Module
- 56K V.34 Fax/Modem
- I/O Port Replicator
- MPEG II Card
- Car Adapter
- Extra memory modules (32, 64, 128MB 144-pin 3.3V SODIMM)
- Li-Ion Main Battery Pack
- Li-Ion Secondary Battery Pack (same main battery)

## **Unpacking & Checking the Equipment**

---

Before unpacking the Notebook, prepare a clean, stable surface on which to place the contents of your Notebook's shipping container. Altogether, you should find the following items in the Notebook package:

- The Notebook Computer (with one battery pack already installed)
- Installed Combo Module (FDD/CD-ROM or FDD/DVD)
- An AC Adapter
- A Power Cord
- A Carrying Bag (optional)
- Support Diskettes
- This User's Manual

Remove all the items from the container. If anything is missing or broken, inform your dealer immediately. You should save the packaging; if you ever need to ship your Notebook or send it in for service, the shipping container will definitely be useful.

## Identifying Parts of the Notebook

---

The illustrations that follow identify the various features and external components of the Notebook computer. Familiarizing yourself with these terms will help you as you read the rest of the manual.

### Right Front View (Panel Closed)

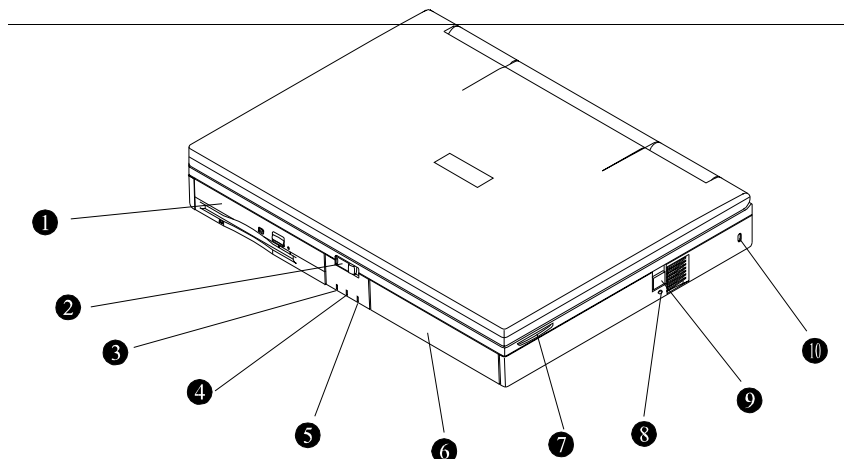

*Figure 1-1: Right Front View with Display Panel Closed*

#### 1. Combo Module (FDD/CD-ROM)

Your Notebook comes equipped with a factory-installed Combo module. The Combo Module contains an FDD and CD-ROM in one removable case. Insert 3.5-inch floppy diskettes into the lower floppy disk drive. Note the two eject buttons: the upper button ejects the CD-ROM tray; the lower button ejects a diskette from the floppy disk drive. The lower eject button only pops out when a diskette is inserted into the drive. The Combo Module can be removed and replaced with a different module. See the section, *Installing and Removing Modules* in Chapter 6, for a detailed description of installing and removing the Combo module.

#### 2. LCD Panel Release Button

To open the Notebook, slide this release button to the right. This will release the LCD panel latch. Now raise the panel to its open position as shown in *Figure 1-4*. Note that the Notebook's LCD panel can be adjusted to an angle ranging from 0° to 180°. Adjust the LCD panel for a comfortable viewing angle.

### **3. Power Indicator**

This LED will light when the Notebook is powered on. Refer to Chapter 3, *LED Status Indicators* for more information on the Power Indicator.

### **4. HDD Indicator**

This LED will light when the hard disk is being accessed.

### **5. Battery Indicator**

This LED will blink when the battery is charging. Refer to Chapter 3, *LED Status Indicators* for more information on the Battery Indicator.

### **6. Removable Battery Module**

Your Notebook comes equipped with a factory-installed battery pack module. After the battery runs down, the module can be removed and replaced with a charged battery. Additional battery packs can also be purchased as optional equipment.

### **7. Internal Stereo Speaker**

The Notebook provides three audio-output choices: wearing headphones connected to the audio Headphone-out jack for private listening; connecting external stereo speakers to the audio Headphone-out jack for high quality sound; or for convenience, using the internal stereo speakers.

### **8. Power Kill Button**

Pressing this button will shut down the system. All unsaved data will be lost.

### **9. RJ-11 Modem Port (optional)**

Connect a phone line to this port to make use of the Notebook's optional Fax/Modem. Refer to Chapter 4, *Peripherals* for more information. Note: this port will be covered if an internal Modem (factory option) is not installed.

### **10. Kensington Lock**

This port is for locking the Notebook PC to a desk for security.

## **Left Front View (Panel Closed)**

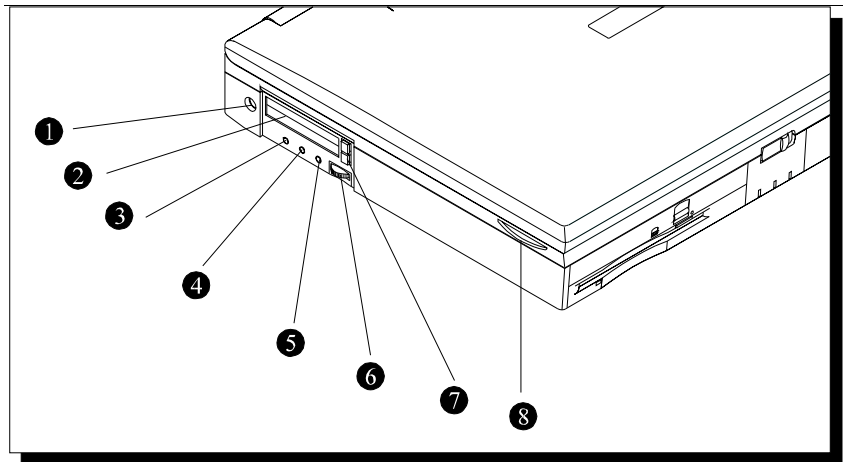

*Figure 1-2: Left Front View with Display Panel Closed*

**1. AC Power Jack**

Connect the AC Adapter power cord to this jack.

**2. PCMCIA sockets**

Insert PCMCIA Type I, Type II, or Type III cards into these sockets.

**3. Audio Line-in Connector**

This stereo jack is used to connect an external audio source to the Notebook.

**4. External Mic Connector**

This stereo jack is used to connect an external microphone.

**5. Audio Headphone-out Connector**

This stereo jack is used to connect external speakers or headphones. Please refer to Chapter 3 for information on using Audio control hot keys.

**6. Hardware Master Volume Control**

This control regulates the audio volume output.

**7. PCMCIA Socket Eject Buttons**

Push the upper button to release a PCMCIA Type I or Type II card from the upper slot. Push the lower button to release a PCMCIA Type I, Type II, or a Type III card from the lower socket.

## 8. Internal Stereo Speaker

See *Figure 1-1* for a description of the internal stereo speakers.

*Note:* The Audio jacks are three-terminal stereo jacks but are not compatible with two-terminal mono plugs. They are not compatible with two-terminal mono plugs.

## Rear View

The rear side of the Notebook contains an FIR (fast infrared) port, a serial (COM) port, a Parallel (LPT1) port, a VGA port, a PS/2 mouse/external keyboard port, a USB port, TV out port, and a 240-pin I/O Docking connector.

Starting from left to right, the rear-side ports are introduced below. Please refer to *Figure 1-3* for assistance in locating these ports.

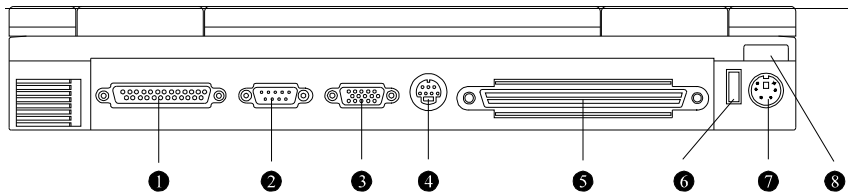

*Figure 1-3: Rear View of Notebook*

### 1. Parallel (LPT1) Port

This port is normally used to connect a printer to the Notebook.

### 2. Serial (COM) Port

This port is used to connect RS-232 serial devices to the Notebook. Three types of serial devices are mice, serial printers, and modems.

### 3. VGA Display Port

This port is used to connect an external monitor (CRT) to the Notebook.

### 4. TV-out Port

Connect a Television set to this port to view the Notebook's display output on your TV.

### 5. Docking Station Connector

This port is for connecting the Notebook to its proprietary Docking Station or I/O Replicator.

### 6. Universal Serial Bus (USB) Port

Connect any USB compliant device to this port.

### 7. External Keyboard or PS/2 Mouse Port

This port is for connecting either an external keyboard or a PS/2 mouse.

### 8. FIR Port

The FIR Module allows wireless communication (transmission and receiving) between the Notebook and another FIR-equipped computer or between the Notebook and another FIR-equipped device, such as a printer.

## Right Front View (Panel Open)

Open the Notebook by first sliding the latch located on the front of the Notebook to the right. Please refer to *Figure 1-1* to locate the LCD panel release button. Raise the cover to its open position. *Figure 1-4* shows the Notebook in the open position with the external parts labeled. As mentioned earlier, the cover can be adjusted to an angle of 0° to 180°. Adjust the LCD cover for a comfortable viewing angle.

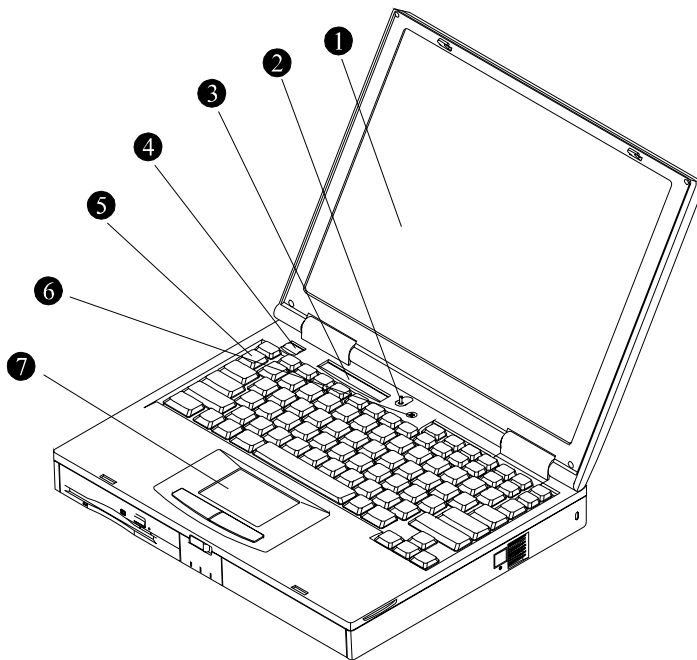

**Figure 1-4: Right Front View with Display Panel Open**

#### 1. LCD Screen

The screen is a color TFT LCD.

## 2. Suspend/Resume Lid Switch

There  
automa  
based u  
program  
It is cov  
In the  
switch.  
the No  
omatica  
In the t

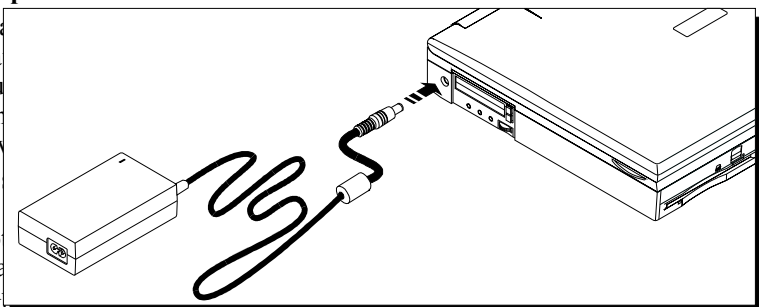

key. Pressing [Fn] + [R] suspends to RAM, and pressing [Fn] + [F12] suspends to disk. The user can press the power button to resume full power operation.

For more information on Suspend modes, please see Chapter 5, *Power Management Modes*.

## 3. System Status Window

The System Status window informs you of the Notebook's current operating status at a glance. The different display icons that may appear in this window are: Caps Lock, Numlock, Scroll Lock, Keypad Lock, FDD activity, PCMCIA activity, CD-ROM and HDD activity, AC power, Main battery or Secondary battery icon and the Battery power status icon.

## 4. On/Off Button

Press this button to turn the computer on or off.

## 5. Keyboard

Your keyboard is either an 87-key US version or an 88-key international version depending on the Notebook you purchased.

## 6. Built-in Microphone

The microphone can be used to record music, voice, and sound files.

## 7. Touch Pad

The Touch Pad is a pressure sensitive pointing device that provides all the features of a mouse. Although its operation differs from a mouse, its function is quite the same; to move the cursor around the screen. Please refer to *Using the Touch Pad*, in Chapter 3 for more information.

# Installation and Initial Setup

---

If you are unfamiliar with computers, this section guides you through turning on your Notebook for the first time. This section also explains what you need to do after turning on your Notebook. Experienced computer users may need

only read this section while using the rest of the manual merely as a reference.

## Connecting the AC Power Adapter

There are two possible ways of powering the Notebook. One is by an internal battery module and the second is by connecting the Notebook's AC Adapter. This chapter will focus on the AC connection. *Figure 1-5* and *Figure 1-6* illustrates this connection. For information on using battery power, please refer to Chapter 5.

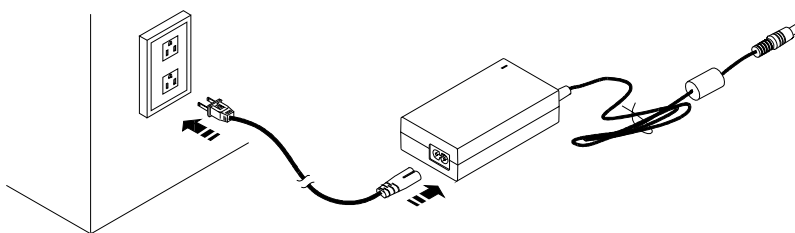

*Figure 1-5: Connecting the Power Cord to the AC Adapter*

## An AC Connection

To power the Notebook by using the external AC Adapter, please refer to *Figure 1-5*, *Figure 1-6* and the following instructions:

1. Insert the end of the AC Adapter output cable into the Notebook's AC port. *Figure 1-6* illustrates this connection. Do not force a connection.
2. The port on the AC Adapter module is shaped like a figure eight with two pins protruding from it. Connect the power cable to this port.
3. The best power source that you can connect any computer device to is a UPS (uninterruptable power supply). Your Notebook dealer will be able to provide you specifics as far as the price and performance of different brands of UPS devices. If you do not own a UPS and have no desire to purchase one, your next best power source is an extension cord that has its own built-in electrical surge protector. Lacking this kind of extension cord, plug the AC Adapter directly into a grounded electrical outlet.
4. Plug the Notebook into its power source and press the On/Off button. If the Notebook does not power up, check the connections between the wall outlet, the AC Adapter, and the Notebook. If the Notebook still does not power up, please refer to Appendix A, *Troubleshooting*.
5. To turn the Notebook off, save your work and close all open applications, click on **Start**, then **Shut Down**. In the **Shut Down Windows** dialog box

select **Shut down the computer** and click *Yes*.

---

**Figure 1-6: Connecting the AC Adapter to the Notebook**

If you travel to an area with a different electric power standard, check to make sure whether that voltage system is compatible with your Notebook's power requirements before plugging it into an AC power source. You can use an adapter plug that interfaces between your system cables and the electrical wall outlet of the foreign country you are visiting. If you are unsure about this, please consult your Notebook dealer or support technician.

Your Notebook is equipped with one rechargeable battery pack, which has already been installed. Please refer to the Power Management section of Chapter 5 for further coverage of the rechargeable battery and how to optimize its use.

## **The Power On Self Test (POST)**

When you turn on the computer, it will first run through a series of software-controlled diagnostic tests called the Power On Self Test (POST). The software that controls the POST is installed as a permanent part of the computer's architecture. The POST includes a record of the computer's hardware that is used to make a diagnostic check of the system. This record is created by using the BIOS Setup program. If the POST discovers a difference between the record and the existing hardware, it will display a message on the screen prompting you to correct the conflict by running the BIOS Setup program. Refer to Chapter 2, for instructions on how to run the BIOS Setup program.

In most cases, the record should be correct when you receive the computer. If so, the POST will finish and the computer will look for an Operating System to load into memory. The self test will run every time you turn on the computer. When the test is finished, you should get a message indicating that there is a non-system disk or disk error. This indicates that the hard disk is ready to be prepared for use with the operating system you intend to use. After you prepare the hard disk for use, you should not see this message again unless you try to start the computer with a non-system floppy disk inserted in the floppy drive.

## **Installing an Operating System**

When starting the computer for the first time, please be aware that you must have an Operating System (OS) program installed on the hard drive. You probably have an OS program already installed on your Notebook. If your dealer did not install an OS for you, please consult your OS Software manuals for instructions on how to install an OS onto your hard disk drive.

## Preparing the Notebook for Transport

To prepare the computer for transport, you should first disconnect all peripherals. Make sure the computer is turned off before you do this. Make sure the floppy drive does not contain a diskette. When a diskette is inserted in the floppy drive, the eject button pops out. If you attempt to transport the Notebook with a diskette in the drive, you risk damaging the eject button.

The computer has an optional soft carrying case. It will keep out dirt and dust and protect the casing of your Notebook from becoming scratched or cracked.

If you intend to use battery power, be sure to fully charge the battery pack and any spares. Remember the Adapter charges the battery pack as long as it is plugged into the computer and an AC power source.

## A Word about Ergonomics

*Ergonomics* is the study of how people with their different physical characteristics and ways of functioning relate to their working environment (the furnishings and machines they use). The goal of Ergonomics is to incorporate comfort, efficiency, and safety into the design of keyboards, computer desks, chairs, and other items in an effort to prevent physical discomfort and health problems in the working environment. Because more and more people are spending large amounts of time in front of computer monitors, scientists from many fields including anatomy, psychology, and occupational safety are involved in the study of ergonomically sound work environments.

If your budget permits, buy ergonomically designed furniture such as chairs, shelves, and desks that fit your physical characteristics and work methods. Most furniture manufacturers have not considered the particular shape of your body when designing workstations. If you are going to be sitting for extended periods, an ergonomically designed chair may well be worth the extra expense. You can, however, create an ergonomically improved workstation without spending much money. Following are a few tips to help you work effectively without a lot of physical discomfort:

- Place the monitor so that it is a little *above* eye level to prevent neck strain.
- Try to place the monitor so that there is little glare from the sun on the monitor.
- Use a thick book as a footrest.
- Walk around the room every hour.
- Every half-hour, look away from the computer screen for a few minutes.
- Place everything that you need to work within easy reach.

This concludes Chapter 1. The next chapter covers the BIOS Setup program.



# CHAPTER 2

## THE BIOS SETUP PROGRAM

### Introduction

---

The BIOS (Basic Input and Output System) Setup program is a menu driven utility that enables you to make changes to the system configuration and tailor the operation of your Notebook to your individual work needs. A ROM-based configuration utility displays the system's configuration status and provides you with a tool to set system parameters. These parameters are stored in non-volatile battery backed-up CMOS RAM, which saves this information even when the power is turned off. When the system is turned back on, the system is configured with the values found in CMOS. Using easy-to-use menus, you can configure such items as:

- Hard drives, diskette drives and peripherals
- Video display options
- Password protection from unauthorized use
- Power Management Features

The settings made in the Setup program intimately affect how the Notebook performs. It is important, therefore, first to try to understand all the available options, and second, to make settings appropriate for the way you use the Notebook. This chapter will guide you through the Setup program by providing clear explanations for all Setup options.

A standard configuration has already been set in the Setup program by the factory technicians, so you will very likely have little to worry about for now. However, eventually you may want to customize your system to suit your own performance needs. It is recommended that you read this chapter and become familiar with the adjustments that can be made in the BIOS.

The next section discusses how to move around in the Setup program, as well as how to specify and save your new settings. A brief discussion of the optional settings among the different submenus follows.

## **Navigating through the BIOS Setup Program**

The Setup program has been designed to make it as easy to use as possible. It is a menu driven program, which means you can scroll through the various directories and make your selections among the various predetermined choices. If you accidentally make a setting and do not know which one to switch back to, use the BIOS hot keys to return to the previous value. The hot keys are discussed in more detail later in this chapter.

When turning on the Notebook for the first time you may get a message prompting you to run the BIOS Setup program. A warning message may appear on the screen if the hardware configuration is changed or the POST fails. This message will inform you of any errors or invalid settings and prompt you to run the Setup program to correct the problem.

Even if you are not prompted by a message instructing you to use the Setup program, at some time in the future you may want to change the configuration of your computer. For example, you may want to make changes to the power management settings or enable the Notebook's password function for security purposes. It will then be necessary to reconfigure your system using the Setup program so that the computer can recognize these changes.

The list below gives a few examples of reasons why you may want or need to run the BIOS Setup program.

- You have set up the computer for the first time and you got a message stating that you should run the BIOS Setup program
- You want to redefine the communication ports to prevent any conflicts
- You want to make changes to the Power Management configuration
- You want to change the password or make other changes to the security setup

*The few examples listed above are by no means a complete list.*



## Accessing the BIOS Setup Program

To access the BIOS Setup program, press the F2 key after the Notebook has run through its POST.

### The Menu Bar

The top of the Setup screen has a menu bar with the following selections:

<b>Main</b>	Use this menu to make changes to the basic system configuration.
<b>System Devices</b>	Use this menu to enable and make changes to the advanced features available on your system.
<b>Security</b>	Use this menu to set System and Boot passwords.
<b>Power</b>	Use this menu to configure and enable Power Management features.
<b>Boot</b>	Use this menu to specify the order in which the Notebook is to check for a device to boot the system.
<b>Exit</b>	Use this menu to specify how to exit the Setup program.

To move between menu bar items, use the [✓] [✓] arrow keys until the desired item is highlighted. For example, if you want to move from the Main menu to the System Devices menu, press the right arrow key [✓] once. The System Devices menu item should now be highlighted.

### The Legend Bar

At the bottom of the Setup screen, you will notice a legend bar. The keys in the legend bar allow you to navigate through the various individual setup menus. The following table lists the keys found in the legend bar with their corresponding functions:

<b>Legend Key</b>	<b>Function</b>
[F1] or [Alt] + [H]	Displays the General Help window.
[Esc]	Exits the current menu and moves you to the Exit menu.
[✓] or [v]	Selects a different menu bar item.
[ ] or [ ]	Moves the cursor up and down between fields.
[Tab]	Cycles the cursor forward through the particular highlighted field. If the field has only one value, the Tab key will move the selection cell down to the next field.
[Shift]+[Tab]	Cycles the cursor backward through the particular highlighted field. If the field has only one value, the [Shift]+[Tab] key combination will move the selection cell up to the previous field.
[F5]	Scrolls backwards through the values for the highlighted field.
[F6]	Scrolls forward through the values for the highlighted field.
[F9]	Sets the parameters for the current active menu to their default values.
[F10]	Saves any changes and exits Setup
[Enter]	Executes commands or selects a submenu.

## Launching Submenus

A submenu contains additional options for a field parameter. To call up a submenu, simply move the highlight to the desired field and press the [Enter] key. The submenu will then immediately appear. Use the legend keys to enter values and move from field to field within a submenu just as you would within a menu.

If you are a first time user or are not familiar with BIOS Setup programs, it is highly recommended that you take a few minutes to familiarize yourself with each of the legend keys and their corresponding functions. Practice navigating through the various menus and submenus. If you accidentally make unwanted changes to the current configuration, pressing the function key [F9] will return the activated menu to its factory set values.

Note that on the right side of each of the BIOS screens there is a section labeled *Item Specific Help*. While moving around through the Setup program, explanations for the currently highlighted field appear in the *Item Specific Help* window.

## General Help

In addition to the Item Specific Help window, the BIOS Setup program also provides a General Help screen. This screen can be called up from any menu by simply pressing the function key [F1], or the [Alt] + [H] combination. The General Help screen lists the legend keys with their corresponding alternates and functions.

When a scroll bar appears to the right of a help window, this indicates that there is more information to be displayed that will not fit in the window. Use the [Page Up] and [Page Down] keys or the up and down arrow keys [ ] [ ] to scroll through the entire help document. Press [Home] to display the first page. Press [End] to go to the last page. To exit the help window, press the [Enter] or the [Esc] key.

## **Saving Changes and Exiting the Setup Program**

Refer to the Exit Menu section of this chapter for detailed information on saving changes and exiting the Setup program.

## The Main Menu

---

When the Setup program is accessed, the following screen appears:

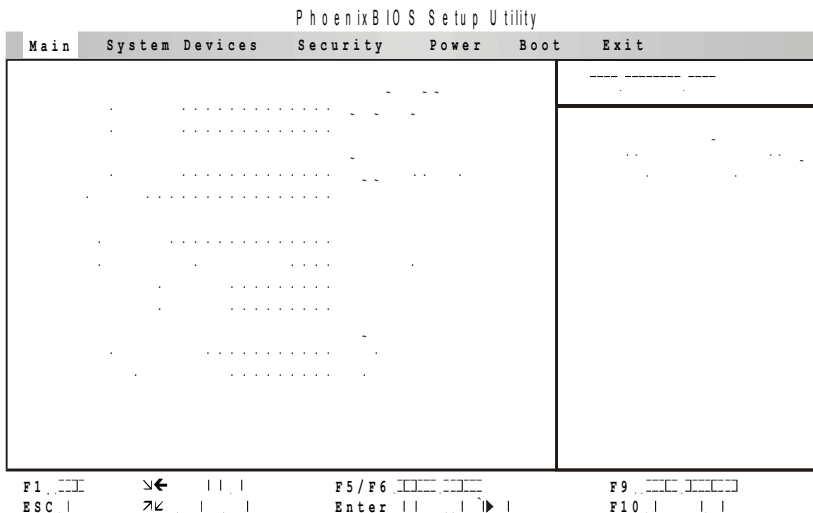

**Figure 2-1: The Setup Main Menu**

Enter the Main Menu of the BIOS setup program to make changes to the Notebook's basic system configuration. Each of the fields displayed in this menu is covered below in detail.

### System Time

Sets your system to the time that you specify (usually the current time). The format is hour, minute, and second. Insert the appropriate information. Use the tab key to move between the hour, minute, and second fields.

### System Date

Sets your system to the date that you specify (usually the current date). The format is month, day, year. Type in the appropriate information. Use the tab key to move between the month, day, and year fields.

### Floppy Drive

Specifies a drive type for diskette drive A. The system will automatically detect the existence of an FDD module. You do not need to make changes to this field. This is a display only field.

## **Hard Disk**

The number value in this field indicates the size of your Notebook's hard drive. The system will automatically detect the size of your hard drive. You do not need to make changes to this field. This is a display only field.

## **Quiet Boot**

This field allows you to display the diagnostic screen during bootup. There are two possible settings:

- Enabled
- Disabled

The default value for this field is: Enabled

When set to *Enabled*, Diagnostic POST and the Summary Screen are disabled. When set to *Disabled*, Diagnostic POST and the Summary Screen are enabled.

## **Video Display Device**

This field allows you to specify the display type options. They are:

- CRT Mode
- LCD Mode
- Simul Mode

***CRT Mode*** allows you to view the Notebook's display on an external CRT monitor.

***LCD Mode*** allows you to view the Notebook's LCD display only.

***Simul Mode*** (Simultaneous Viewing Mode) allows you to simultaneously view the Notebook's LCD display and an external CRT monitor display.

The default value for this field is: Simul Mode

## **Television Port**

This field allows you to enable the TV port, so you can view the Notebook's display on a TV. Available options for this field are:

- Enabled
- Disabled

The default value for this field is: Enabled

### Television Type

This field allows you to choose the television type when connecting the Notebook to a TV. The possible settings are:

- NTSC
- PAL

The default value for this field is: NTSC

### System Memory

This field displays the amount of conventional memory detected by the system during bootup. You do not need to make changes to this field. This is a display only field.

### Extended Memory

This field displays the amount of extended memory detected by the system during bootup. You do not need to make changes to this field. This is a display only field.

## The System Devices Menu

---

Selecting *System Devices* from the menu bar displays the System Devices Menu. Please see **Figure 2-2**.

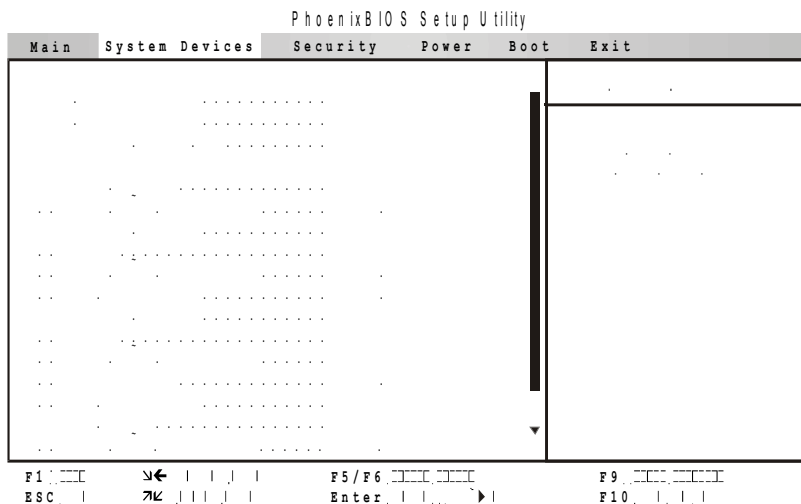

**Figure 2-2: The System Devices Menu**

*Note!* When the Modem Port field is enabled, a scroll bar appears. You need to use the arrow [ ] key to access the rest of the fields.

This menu allows you to configure the Notebook's IDE and FDD controllers, serial and parallel ports, as well as, IR (infrared) and Audio modes. Each field on this menu is covered below.

### **IDE Controller**

This field allows you to configure the IDE Controller for the Notebook's installed hard drives. Available options for this field are:

- Disabled
- Primary
- Both

When *Both* is selected for this field, the IDE Controller will recognize both a primary and a secondary IDE channel. Select *Disabled* if no hard drives are installed. It is recommended that you use the default value for this field.

The default value for this field is: Both

### **FDD Controller**

This field allows you to configure the FDD Controller for the Notebook's floppy disk drive. Available options for this field are:

- Disabled
- Enabled

Select *Disabled* if an FDD is not installed.

The default value for this field is: Enabled

### **Internal MPEG II (Only available if an MPEG II Card is Installed)**

This field allows you to configure your system if you have an internal MPEG II card installed. Available options for this field are:

- Disabled
- Enabled

Select *Disabled* if you do not want to use the internal MPEG II card. This allows you to use a PCMCIA compatible MPEG II card.

The default value for this field is: Enabled

### **Serial Port**

This field allows you to configure the Notebook's serial port. The following options are available:

- Disabled
- Enabled
- Auto

The default value for this field is: Enabled

### **Base I/O Address**

When the Serial Port field is set to *Enabled*, the "Base I/O Address" field becomes available and you can set the serial port's IRQ and I/O address. The following options are available:

- 3F8, IRQ 4
- 2F8, IRQ 3
- 3E8, IRQ 4
- 2E8, IRQ 3

The default value for this field is: 3F8, IRQ4

### **Infrared Port**

This field allows you to configure the Notebook's Fast Infrared (FIR) communication module. The following configuration options are available:

- Disabled
- Enabled
- Auto

The default value for this field is: Disabled

### **Mode**

This field allows you to select the Infrared protocol when the Infrared port is enabled. The following configuration options are available:

- IrDA
- FIR

This field is only available when the Infrared port is set to *Enabled* or *Auto*.

The default value for this field is: FIR

### **Base I/O address**

Use this option to choose the I/O (port) address for the Infrared port. The available options are:

- 3F8, IRQ 4
- 2F8, IRQ 3
- 3E8, IRQ 4
- 2E8, IRQ 3

This field is only available when the Infrared port is set to *Enabled*.

The default value is: 2F8, IRQ3

### **DMA Channel (Only Available for Fast IR Mode)**

This field allows you to configure the Infrared port's DMA Channel. The following options are available:

- DMA 0
- DMA 2
- DMA 3

This field is only available when the Infrared Port Mode field is set to *FIR*.

The default setting is: DMA 3

### **Parallel Port**

This field allows you to configure the Notebook's parallel port. The following options are available:

- Disabled
- Enabled
- Auto

The default value for this field is: Enabled

*Note!* Changing the default address and IRQ settings for the Serial Infrared Port and the Parallel Port can cause conflicts with other system devices or installed peripherals.

### **Mode**

This field allows you to configure the Notebook's parallel port transmission mode. The following options are available:

- Normal Mode
- Bi-directional
- ECP
- EPP

Normal mode allows data output only. However, EPP and ECP are Bi-directional modes, allowing both data input and output. The EPP and ECP modes are only supported with EPP and ECP aware peripherals.

The default value for this field is: ECP Mode

### **Base I/O address**

Use this option to choose the I/O (port) address for the Parallel port. The available options are:

- 378
- 278
- 3BC

This field is only available when the Parallel port is set to *Enabled*.

The default setting is: 378

### **Interrupt**

Use this field to set the interrupt (IRQ) for the Parallel port. Available options are:

- IRQ5
- IRQ7

The default setting is: IRQ7

### **DMA Channel (Only Available for ECP Mode)**

This field allows you to configure the Parallel port's DMA Channel for ECP mode. The following options are available:

- DMA 0
- DMA 2
- DMA 3

This field is only available when the Parallel Port Mode field is set to *ECP*. The default value for this field is: DMA 3

### **Modem Port (Only Available if a Modem is Installed)**

This field allows you to configure the Modem port. The following options are available:

- Disabled
- Enabled
- Auto

The default value for this field is: Disabled

### **Base I/O address**

Use this option to choose the I/O (port) address for the Modem port. The available options are:

- 3F8, IRQ 4
- 3E8, IRQ 4
- 2E8, IRQ 3
- 2F8, IRQ 3

This field is only available when the Modem port is set to *Enabled*. It is recommended that you use the default value for this field.

The default setting is: 2F8, IRQ3

### **Configuration port**

Use this option to set the Modem configuration port. The available options are:

- 130
- 138
- 140
- 148

This field is only available when the Modem port is set to *Enabled*. It is recommended that you use the default value for this field.

The default setting is: 130

### **16-bit DMA Channel A**

This field allows you to configure the Modem port's DMA Channel A for *voice device*. The following options are available:

- DMA 5
- DMA 6
- DMA 7

This field is only available when the Modem Port Mode field is set to *Enabled*. The default value for this field is: DMA 6

### 16-bit DMA Channel B

This field allows you to configure the Modem port's DMA Channel B for *voice device*. The following options are available:

- DMA 5
- DMA 6
- DMA 7

This field is only available when the Modem Port Mode field is set to *Enabled*. The default value for this field is: DMA 7

## The Security Menu

---

The Notebook's advanced system of security allows you to set a password to prevent unauthorized access to system resources, data, and the BIOS Setup program. This section covers each parameter of the Security Menu. Selecting *Security* from the menu bar displays the following menu:

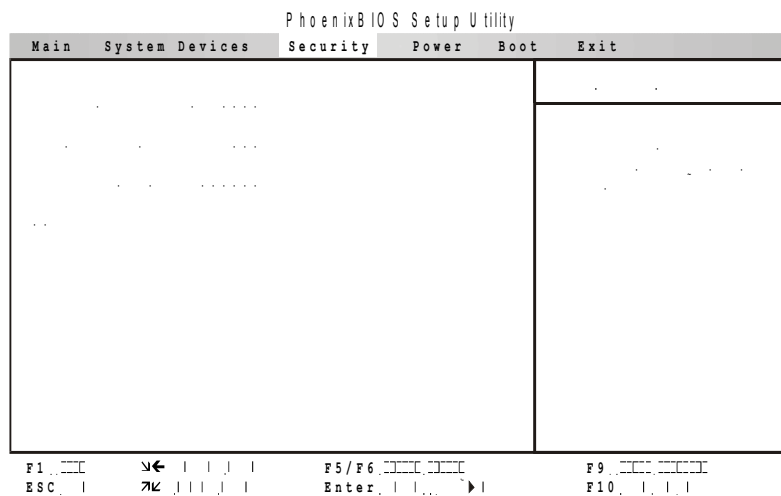

**Figure 2-3: The Security Menu**

Each field of the Security Menu is covered in detail below.

### **A Note about Passwords**

The BIOS Setup program allows you to specify passwords in the Security menu. The passwords control access to the BIOS and certain Security menu options during system startup. The passwords are not case sensitive. In other words, a password can be entered using either upper or lower case letters; it makes no difference.

### **System Password is**

This field will show *Set* when you have set a System Password as described below. If you have not set the System Password, the field will show *Clear*. This is a display only field.

### **Set System Password**

This field allows you to set the System Password. The System Password allows full access to the BIOS Setup menus. To set the password, highlight this field and press the [Enter] key. The following dialog box appears:

<b>Set System Password</b>	
<b>Enter New Password</b>	[ ██████████ ]
<b>Confirm New Password</b>	[            ]

Type the password and press the [Enter] key. You can type up to eight alphanumeric characters. Symbols and other keys are ignored. To confirm the password, type the password again and press the [Enter] key. The System password is now set. Note that the “System Password is” field automatically changes to *Set*.

To change or clear a password, highlight this field and press the [Enter] key. The following dialog box appears:

<b>Set System Password</b>	
<b>Enter Current Password:</b>	[ ██████████ ]
<b>Enter New Password:</b>	[            ]
<b>Confirm New Password:</b>	[            ]

Enter the current password, then enter the new password, and finally confirm the new password. To clear the password, enter the current password, then press the [Enter] key twice. The password is now cleared and the “System Password is” field is automatically set to *Clear*.

When changing or clearing the password a “Setup Notice” will inform you that changes have been saved. Press the [Enter] key to register your changes.

### Password On Boot

When enabled, the system will then require the password before the system can bootup. The options for this field are:

- Disabled
- Enabled

The default value for this field is: Disabled

## The Power Menu

The Power Menu of the Setup program allows you to enable and adjust the advanced features of the Notebook designed to conserve power. Enabling these features will extend the life of the battery pack between charges. To make changes to power management settings, select *Power* from the menu bar. The following menu appears:

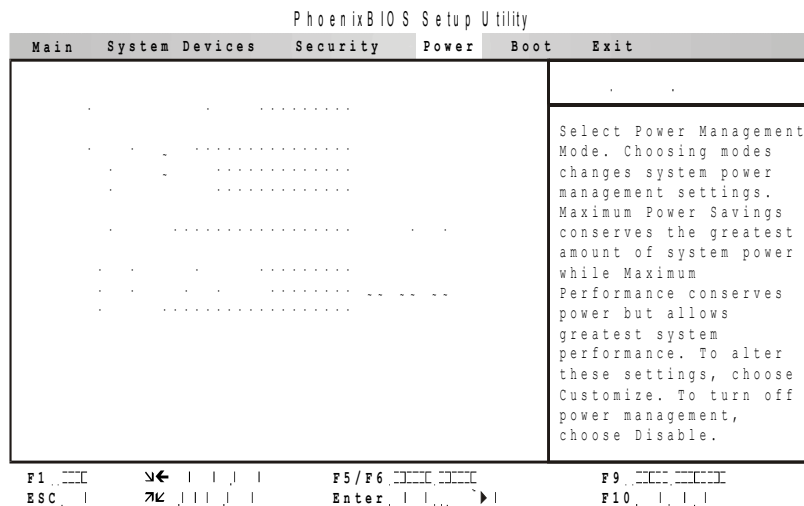

Figure 2-4: The Power Menu

### Power Management Mode

This menu item allows you to set power management features with pre-defined values. The available options for this field are:

- Disabled
- Customized

- Max. Power Savings
- Max. Performance

If this menu item is set to *Disabled*, power management features will not function regardless of other field settings on this menu.

The *Customized* option allows you to make your own selections from the following fields within the Power Menu.

When this field is specified as *Max. Performance*, optimal system performance is achieved with some power conservation. The remaining fields within the Power Menu will be set to pre-defined values that ensure maximum performance.

When set to *Max. Power Savings*, system power will be conserved to its greatest amount. The remaining fields within the Power Menu will be set to pre-defined values that ensure maximum power savings.

The default value for this field is: Customized

### **Smart CPU Mode**

This field allows you to enable the CPU Idle Mode. CPU Idle Mode slows down the CPU during brief periods when the system is not busy. Power Management must be enabled for this field to be active.

The available settings for this field are:

- On
- Off

The default value for this field is: Off

### **Standby Time-out**

This menu item allows you to specify how much time of inactivity must elapse before the system automatically transits to Standby mode. In Standby mode, all devices are powered off and the system enters a low power CPU state. Available options for this field are:

- Disabled
- 1 Minutes
- 2 Minutes
- 4 Minutes
- 6 Minutes
- 8 Minutes
- 12 Minutes

- 16 Minutes

This field can only be set when the “Power Management Mode” field is set to *Customized*. The default value for this field is: Disabled

### **Suspend Time-out**

This field determines the amount of time the system needs to be in Standby mode before entering the Suspend to RAM mode. In this mode, all system states are saved to RAM before entering Suspend mode. When set to *Disabled*, the system cannot suspend operations. The possible settings for this field are as follows:

- Disabled
- 5 Minutes
- 10 Minutes
- 15 Minutes
- 20 Minutes
- 30 Minutes
- 40 Minutes
- 60 Minutes

This field can only be set when the “Power Management Mode” field is set to *Customized*. The default value for this field is: Disabled

### **Suspend Mode**

This field determines if the system suspends to RAM or suspends to Disk.

The available options for this field are:

- Save To RAM
- Save To Disk

This field can only be set when the “Power Management Mode” field is set to *Customized*. The default value for this field is: Save To RAM

### **Resume On Modem Ring**

When this field is set *Enabled*, a modem ring will cause the system to resume from Suspend mode.

- Disabled
- Enabled

The default value for this field is: Disabled

### **Resume On Time of Day**

This option allows you to enable the system to resume at a specific time. The possible options are:

- Disabled
- Enabled

If you set this field to *Enabled*, you must set the *Resume Time* field as well.

The default value for this field is: Disabled

### **Resume Time**

This option allows you to specify the time the system will resume. Enter the time in hours, minutes and seconds in a 24-hour format. For example, indicate that the system should resume normal operation at 1:00 p.m. by setting this field with a value of 13:00:00 hours.

## The Boot Menu

The Boot Menu allows the user to specify the order in which the Notebook is to check for a device to boot the system. To make changes, select *Boot* from the menu bar. The following screen appears:

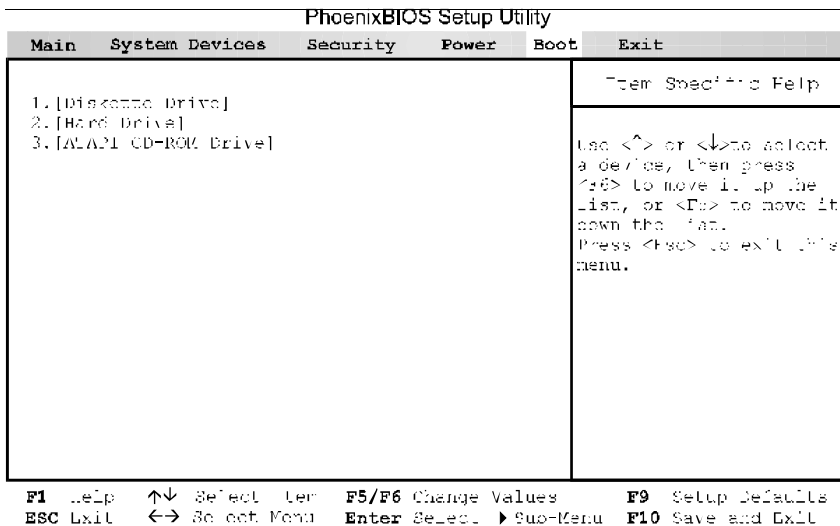

**Figure 2-5: The Boot Menu**

### Boot Sequence

The Boot Menu allows you to use the up and down arrow keys to select among the three possible boot devices listed. By using the [F6] and [F5] keys, it is possible to alter the priority the system uses to search for the boot device on system power up in numerical order.

## The Exit Menu

---

Once you have made all of your selections from the various menus in the Setup program, you should save your changes and exit Setup. Select *Exit* from the menu bar to display the following menu:

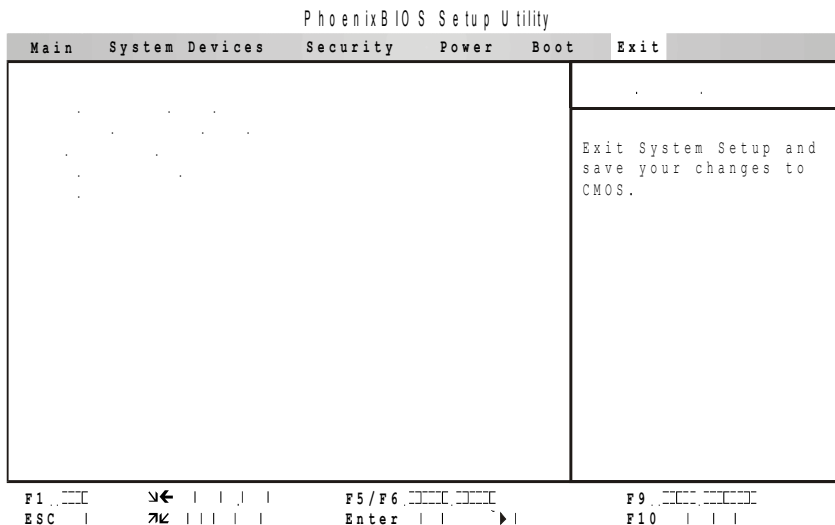

**Figure 2-6: The Exit Menu**

*Note!* Pressing the [Esc] key does not exit this menu. You must select one of the options from this menu or a menu bar item to exit this menu.

Each of the options on this menu is described below.

### Save Changes and Exit

Once you are finished making your selections, choose this option from the Exit Menu to ensure the values you selected are saved to Non-Volatile RAM. Changes you made to the Setup program must be changed to Non-Volatile RAM in order to make them operative. Non-Volatile RAM differs from standard RAM memory in that it is sustained by an on-board battery and stays on even when the Notebook is turned off.

Once your selections have been saved, the Setup program displays the following message:

<b>Setup Confirmation</b>
<b>Save configuration changes and exit now?</b>
<b>[Yes]                      [No]</b>

The next time you bootup the Notebook, the BIOS will attempt to load the values you saved in Non-Volatile memory. If these values cause the system boot to fail, reboot and press [F2] to enter the Setup program. Once in Setup, you can try to change the values that caused the system boot to fail. If the problem persists, load the default values (see *Get Default Values* below).

*Note!* If you attempt to exit the Setup program without saving your changes, the program will prompt you with a message asking if you want to save your changes before exiting.

### **Discard Changes and Exit**

This option should only be used if you do not want to save the changes you have made to the Setup program. The default is set to No. If you have made changes to the fields other than system date, system time and password, the system will ask for confirmation when choosing *Discard Changes and Exit*.

### **Get Default Values**

This option allows you to load the default values for each of the parameters on the Setup Menus. When this option is selected, the following message is displayed:

<b>Setup Confirmation</b>
<b>Load default configuration now?</b>
<b>[Yes]                      [No]</b>

You can now select *Save Changes and Exit* or make other changes before saving the values to Non-Volatile RAM.

### **Load Previous Values**

This option allows you to discard the selections you have made and restore the values you previously saved. After selecting this option, all selections are updated, and the following message is displayed:

<b>Setup Confirmation</b>
<b>Load previous configuration now?</b>
<b>[Yes]                      [No]</b>

### **Save Changes**

This option saves your selections without exiting the Setup program. You can then return to other menus and make changes. After selecting this option, all selections are saved, and the following message is displayed:

<b>Setup Confirmation</b>
<b>Save configuration changes now?</b>
<b>[Yes]                      [No]</b>

This concludes this chapter on the BIOS Setup program. The next chapter covers operation of the Notebook computer.



# CHAPTER 3

## OPERATION

### Introduction

---

This chapter provides information pertaining to the Video Display Controls of the Notebook used to adjust the appearance of the LCD screen. Also included in this chapter is a brief overview of the keyboard, how the System Window indicator symbols help you to diagnose or determine any of the specific computer activities going on at a given time, and a description of the Touch Pad, FIR module, and the Notebook's audio features.

### Video Display Controls

---

The computer uses special key combinations to control the LCD display's Brightness and Contrast. The key combinations are called hot keys.

**Brightness adjustment:**

1. Press [Fn] + [F1] to decrease brightness.
2. Press [Fn] + [F2] to increase brightness.

**Contrast adjustment:**

(Contrast adjustments do not need to be made for TFT display Notebooks)

1. Press [Fn] + [F3] to decrease contrast.
2. Press [Fn] + [F4] to increase contrast.

## Some Important Keys on the Keyboard

Your Notebook computer features a low-profile keyboard that emulates all the functions of a full-size 101/102 key keyboard including an embedded keypad and a full array of special function keys. This section covers the Notebook's keyboard, and identifies several keys that are commonly used when working with either the Disk Operating System or other software.

The alphanumeric keys located on the keyboard are in the same position as those found on a standard typewriter. The usage of these keys is straightforward. There are some keys such as Scroll Lock, Print Screen, etc., whose functions may be unfamiliar to you. This chapter identifies some of these keys and discusses their functions when used with either the Operating System Software or other application software, such as word processors, spread sheet applications, or database management programs.

In addition, the twelve function keys and how they relate to application software are covered. Try locating these keys on the Notebook. **Figure 3-1** shows the keyboard layout.

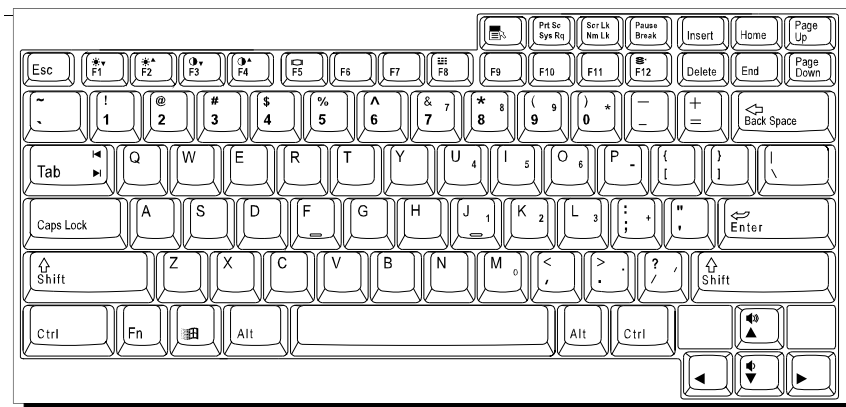

**Figure 3-1: The Keyboard Layout**

1. **[Esc]:** The Escape key allows you to cancel any specific command you may have just keyed in. For example, if you mistakenly hit the function key, [F1], in your word processor or spread sheet program, but want to “cancel” the command so that the computer will ignore the function key, just press [Esc].
2. **[Enter]:** While using application software, the purpose of this key is similar to a typewriter's return key, pressing this key will position the blinking cursor to the beginning of the next line on the display screen.
3. **[Fn]:** This key is located in the lower left corner of the keyboard, next to the [Ctrl] key. Pressing this key engages the alternate function (labeled in blue) on selected keys. For example, simultaneously pressing the [Fn] +

[F1] keys decreases the display brightness.

4. **[PrtSc/SysRq]:** Pressing this key will cause whatever is on the screen at the time to be printed. Note that in some software programs this key may be used in conjunction with other keys for other specific functions. Consult your software user's manual for more information.
5. **[Scr Lk/Nm Lk]:** When Scroll Lock is engaged, pressing the cursor control keys moves the cursor by fields of text. Strike the [Fn] + [Scr Lk/Nm Lk] keys to engage this mode. Striking these keys again will disengage the Scroll Lock function.
6. **[Pause/Break]:** The Break key is used in conjunction with the Control key ([Ctrl] + [Pause/Break]) to cancel a command.
7. **[Caps Lock]:** The [Caps Lock] key corresponds to a typewriter's Shift Lock key, but it only affects letter keys. The number keys and function keys are not affected. Even with the [Caps Lock] key engaged, if you want to generate the symbols and punctuation marks above the number keys, you must still use the [Shift] key. Note that when the [Caps Lock] key is engaged, the Caps Lock Status symbol comes on in the System Window display.
8. **[Shift]:** Similar to the typewriter's Shift key, this key allows you to type letters in "UPPER CASE."
9. **[Ctrl]:** Used by itself, the Control key has no effect in carrying out any commands. Like the [Alt] key, it is always used in combination with other keys. Its function depends mainly upon the type of software you are currently using. Refer to the user's manual of the software you are using for details on how to use this key.
10. **[Alt]:** Used by itself, the Alternate Key has no effect in carrying out any commands, but functions with the [Ctrl] + [Del] key to reboot or restart your operating system program. Refer to the user's guide of the software you are using for more details on how to use this key.
11. **[Windows 95 Keys]** There are two special Windows 95™ keys on the keyboard. These two keys are located next to the Alt keys, on either side of the space bar. The key with the Window 95™ Logo activates the Start menu button on the bottom left of the screen. The other key, which looks like a menu with a small arrow, activates the Properties menu and is equivalent to pressing the right mouse button while pointing at any object on the Windows desktop.

## **Cursor Control Keys and Editing Keys**

---

The keys listed in this section are specifically used to move the cursor on the LCD Display. When used in combination with other keys, these cursor control keys provide some very powerful editing functions.

The cursor will sign...  
 The im... applicat... databas... several... Refer to...  
**Figure**... keys. A...  
 ...pe text on the screen. Having... the screen while editing text...  
 ...s more apparent when using... spread sheet applications, and...  
 ...ating system software (OS),... moving the cursor or editing...  
 ...y to use these keys.  
 ...or Control and Text Editing

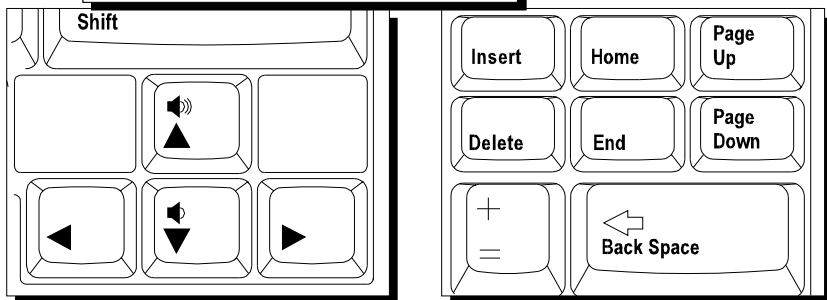

**Figure 3-2: Cursor Control and Text Editing Keys**

1. **[✓] and [✓] Keys:** Pressing either of these keys will move the cursor one character at a time in the direction shown on the arrow key.
2. **[ ] and [ ] Keys:** Pressing either of these keys will move the cursor one line at a time in the direction shown on the arrow key.
3. **[Page Up] or [Page Down]:** These keys allow you to quickly move the cursor on the screen page by page, or window by window, depending on the software you are using.
4. **[Home]:** Refer to your application software manual to find out how your software specifically uses the [Home] key to quickly move the cursor to either the beginning of a document or the beginning of a line.

5. **[End]:** Refer to your application software manual to find out how to use the End key to quickly move the cursor to the end of a line or to the end of a document.
6. **[Insert]:** The Insert key is used mainly for editing. It enables you to insert characters within the text while using DOS. Some applications, however, automatically insert text while within a document, so depending upon the software you are using you may or may not need to use this key.
7. **[Delete]:** This key is used for editing text at either the DOS command prompt or the text within a document. Pressing the Delete key will remove any characters to the right of the cursor and then pull from the right the remaining typed characters.
8. **[Back Space]:** While within a document, the Back Space Key allows you to move the cursor to the left and simultaneously erase characters in its path. Note that this is different from the left arrow key, which will not erase any typed characters.

## The Function Keys

---

Notice the twelve function keys at the top of the keyboard. These keys appear in sequence ([F1], [F2], [F3], . . . [F11], [F12]) from left to right. The functions these keys perform vary with respect to the operating system and software in use. Refer to the appropriate software user's guides for more detailed information for function key definitions.

## Embedded Numeric Keypad

---

An embedded numeric keypad consists of 15 keys that make number intensive input more convenient. These keys have both numeric and cursor movement functions, which are labeled in blue on the keycaps. When the numeric keypad is engaged, the Num Lock icon will appear in the System Window. The keypad is activated in one of two ways:

1. While holding down the [Fn] key, press the [F8] key to toggle the numeric keypad on and off.
2. A second way is to temporarily activate the numeric keypad by holding down the [Fn] key when the Num Lock state is on. The numeric keys will be active as long as you hold down the [Fn] key.

---

*Figure 3-3: The Embedded Numeric Keypad*

## Hot Keys for System Control

The following table lists the hot key functions for the Notebook computer.

Key Combinations	Definitions
[Fn] + [ ]	Increases audio volume output
[Fn] + [ ]	Decreases audio volume output
[Fn] + [F1]	Decreases display brightness
[Fn] + [F2]	Increases display brightness
[Fn] + [F3]	Decreases display contrast (not available on TFT color display panels)
[Fn] + [F4]	Increases display contrast (not available on TFT color display panels)
[Fn] + [F5]	Switches among LCD, external monitor, and simultaneous displays
[Fn] + [F7]	Toggles the mute function on and off.
[Fn] + [F8]	Toggles the embedded cursor/numeric keypad on and off
[Fn] + [F12]	Pressing this hot key combination will cause the system to enter Hibernate mode.
[Fn] + [S]	Pressing this hot key combination will cause the system to enter Standby mode.
[Fn] + [R]	Pressing this hot key combination will cause the system to Suspend to RAM.

## The System Status Window

Located above the keyboard, the System Status window informs you of the Notebook's current operating status at a glance. Please see *Figure 1-4* to locate this display. Upon activating a certain function, a symbol or icon corresponding to that function will appear in the system window until you deactivate that feature. The symbol will remain in the window indicating that the feature is engaged.

*Figure 3-4* shows the "System Status window" with all the symbols that can be displayed. A description of each of the icons is listed below.



*Figure 3-4: The System Window*

Notice the first icon that appears in the left of the System Status window consists of five separate symbols. They are explained in detail in the order in which they appear.

### **Caps Lock**



Upon pressing the [Caps Lock] key, this icon appears in the System Status window indicating that the Caps Lock feature is engaged. Press the [Caps Lock] key again to deactivate this feature and turn off the icon.

### **Num Lock**



Upon pressing the [Scr Lk/Nm Lk] key, this icon appears in the System Status window indicating the embedded keypad's numeric feature is activated. Press the [Scr Lk/Nm Lk] key again to deactivate this feature and turn off the icon.

### **Pad Lock**



The pad lock or keypad icon appears in the System Status window when you press the Notebook's [Fn] key indicating the keypad's cursor function is engaged. The icon disappears when you release the [Fn] key indicating the cursor function is no longer activated. Another way to turn the keypad icon on is by pressing the [Fn] + [F8] keys. When this is done, the keypad is locked and its numeric feature is engaged.

The keypad lock status can be temporarily disabled by pressing and holding down the [Fn] key. The keypad lock status is enabled again when the [Fn] key is released. The keypad icon disappears when you press the [Fn] + [F8] keys again, indicating the keypad lock is no longer activated. When the Pad Lock icon appears in the System Status window, the embedded keypad will be active.

### **Scroll Lock**



Upon pressing the [Fn] + [Scr Lk/Nm Lk] key, this icon appears in the System Status window indicating the scroll lock is engaged. Press the [Fn] + [Scr Lk/Nm Lk] key again to deactivate this feature and turn off the icon.

### **Combo (CD-ROM/FDD or DVD/FDD) Activity**



When this icon appears in the System Status window, it indicates that the CD-ROM or the hard disk is being accessed.

### **FDD Activity**



When this icon appears in the System Status window, it indicates that the internal floppy disk drive is being accessed.



### PCMCIA Activity

When this icon appears in the System Status window, it indicates that a PCMCIA card is being accessed.



### AC Power

This icon indicates that the Notebook is being powered by an external AC source. If the icon is OFF, the system is off and the battery is not being charged. If the icon is ON, the system is on and the battery is not being charged. When the AC Power Icon is blinking, the battery is being charged.



### Main/Secondary Battery

The upper icon indicates the main battery status while the lower icon indicates the secondary battery status. When either icon is OFF it indicates that the corresponding battery (Main or Secondary) is not installed. When either of the icons is ON, it indicates that the corresponding battery is installed but inactive. When either of the icons is blinking (at a rate of once per second), it indicates that the corresponding battery is installed and active.



### Battery Life Status

Notice there are ten vertical lines in the battery icon. Each line indicates approximately 10% battery life. If all ten lines are showing, this indicates that the battery is fully charged with 100% battery life. Nine vertical lines indicate approximately 90% battery life is remaining. When there is only one vertical line, approximately 10% battery life is remaining; this is referred to as the low battery state. At this time, there will be approximately 10-20 minutes of battery power left. When there are no vertical lines showing, the battery has entered the critically low state. The system beep will begin to sound, reminding you to save your data to HDD or floppy diskette. Press [Fn] + [F7] to disable the system beep. Failure to save your data now could result in a serious loss of time and effort.



### Defective Battery

If the Notebook is being operated on AC power and this icon appears in the System Status window, it indicates that the battery is defective. The system will not charge a defective battery.

If the Notebook is being operated on battery power and this icon appears in the System Status window, it indicates there is very little battery life remaining. You should immediately begin saving any unsaved data to HDD or FDD.

If the Notebook is operating on battery power and this icon is flashing in the System Status window, it indicates the battery has entered the critically low

state. Save your work, replace the battery with a fully charged one, or if available use AC power.

### Over Temperature Protection Feature



The AC power is flowing to the Notebook, however, the battery is not being charged. This is an over-temperature protection feature for batteries. The system will not charge the battery under the following conditions:

- The battery temperature is over 50°C when the system begins to charge the battery.
- While charging the battery, the battery temperature exceeds 60°C. In this condition, the charging process stops until the battery temperature falls below 50°C; it will then begin charging again.

### Battery Charge



The gas gauge icons scroll from left to right when the battery is charging.

## LED Status Indicators

---

The Notebook has three LED indicators. This section describes each of these indicators.

### Power Indicator

The following table describes this status indicator.

Color	State	Meaning
Green	On	The Notebook's power is on.
Green	Off	The Notebook's power is off.
Amber	On	The Notebook is in Sleep or Suspend to RAM mode.
Amber	Off	Not in power management mode.

### HDD/FDD/CD-ROM/PCMCIA Access Indicator

The following table describes this status indicator.

Color	State	Meaning
Green	On	The HDD/FDD/CD-ROM/PCMCIA is being accessed.
Green	Off	The HDD/FDD/CD-ROM/PCMCIA is not being accessed.

### **Battery Charge Indicator**

The following table describes this status indicator.

<b>Color</b>	<b>State</b>	<b>Meaning</b>
Green	On	Stop charge by Battery full, Bad cell, over temperature or charging protection.
Green	Flashing	The battery is charging.
Green	Off	The battery is discharging or no Battery.

## Battery Charging Control

---

When the AC Adapter is plugged in, the main battery will always be the first to receive a charge. After the main battery is charged to capacity, the secondary battery will then be charged, assuming it is installed.

If the Notebook is not being charged by AC power, the secondary battery, assuming one is installed, will be the first battery to be discharged. After the second battery runs down, the system will begin using the main battery.

If an over 60°C temperature condition occurs while charging the main battery, the process will be stopped. The system will then search for a secondary battery pack, and if located, will begin to charge it. Once the secondary battery charging process commences, even if the main battery temperature falls below 50°C, the system will not switch to charging the main battery until the secondary battery is completely charged.

## Using the Touch Pad

---

The Touch Pad is a touch-sensitive pointing device that provides all the features of a mouse. Please refer to *Figure 3-5* and the following explanation for the Touch Pad's operating instructions.

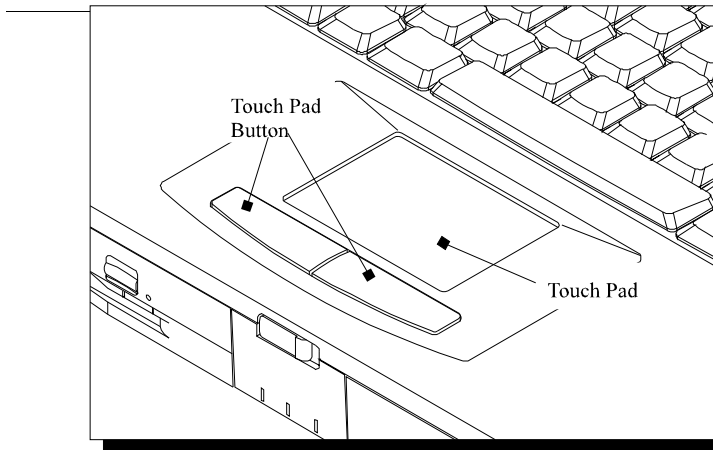

*Figure 3-5: The Touch Pad*

Please refer to the following for instructions on how to operate the Touch Pad.

1. Place your fingers on the keyboard in the normal typing position.
2. The Touch Pad is easily accessible by moving either your left or right thumb off the space bar and on to the Touch Pad.
3. Gently move your thumb across the Touch Pad in the direction you want the cursor to move. The pad detects the change in pressure and moves the cursor in the corresponding direction.
4. With a conventional mouse, selections are usually made by double-clicking the mouse's left button. The Touch Pad also supports this feature. It is described in detail below. If you are familiar with the operations of a mouse you may only need to scan the information below as a review.

The Touch Pad buttons have essentially the same function as mouse buttons. Clicking these buttons makes selections, drags objects, or performs a variety of other functions depending on the software. To select an object, first move the pointer over the object you want to select, and then press the lower button one time and release it. The functionality of these buttons depends on your software. Refer to your software user's manuals for specific information on the Touch Pad (mouse) functions.

*Double-clicking* is a common technique for selecting objects or launching programs from icons. Once you have moved the pointer over the object you wish to select, then rapidly press the left button two times. This action is commonly referred to as "double-clicking on an object."

*Double-tapping* is another technique for selecting objects or executing applications from icons. For the most part *double-tapping* is very similar to the *double-clicking* technique of a mouse. The difference is that instead of *double-clicking* on a mouse button, you *double-tap* on the pressure sensitive Touch Pad to make the selection. Once the cursor has been moved to the object you want to select, lightly double-tap the pressure sensitive Touch Pad itself. This double-tapping will select the desired item and prompt the software to perform the related operation.

Many of the functions within Windows 95 can also be launched by using *Single-tapping*. Once the cursor has been moved to the object you want to select, lightly single-tap on the pressure sensitive Touch Pad. This single-tapping will select the desired item and prompt the software to perform the related operation.

When working with programs that employ a graphical user interface (GUI), such as Windows, *dragging* objects from one point on the screen to another is a technique you will have to master. To drag an object, first move the pointer over the object, then press and hold down the left button. Now without releasing the button, move the object to a new location on the screen by

moving your finger across the Touch Pad. Once the object is in the desired position, release the button to drop the object in place.

## The FIR Module

---

The Notebook is equipped with two FIR modules located on the rear and front panels. Please see **Figure 3-6** if you are having trouble finding these modules. The FIR (Serial Infrared) module consists of one Light Emitting Diode (LED) and one photo sensor. The operation of the FIR module is similar to the operation of a television remote control device. The LED functions as a transmitter and the photo sensor acts as a receiver. The transmitter emits a signal stream consisting of data as pulses of infrared light. The receiver picks up pulses of infrared light transmitted by other FIR

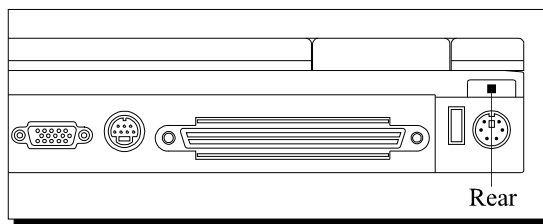

modules.

---

**Figure 3-6: The FIR (Fast Infrared Modules)**

The FIR module allows wireless, serial communication between the Notebook and other FIR equipped devices such as a printer or another computer. Use an IR-specified application to transmit or receive data via the Notebook's FIR module.

Follow the guidelines listed below when using the FIR module to transmit or receive data.

- Make sure the "Infrared Port" field under the System Devices menu in the BIOS Setup program is set to an available address. The "UART 2 MODE" field should be set to *Fast IR* and the "Fast IR DMA Channel" should be configured for *DMA 0*. Refer to Chapter 2 for information on the BIOS Setup program.
- Ensure that the Notebook's FIR module is properly lined up with the other device's FIR module. The FIR baud rate can reach 115,200 at a distance of 1 meter and a bias angle of 15°. The transmission distance can be further lengthened by reducing the baud rate or by perfectly aligning the two devices.
- There should be a clear, unobstructed path between the two FIR modules; otherwise, the optical signal will be blocked. Likewise, do not place

anything between the two FIR modules during data transmission.

- Do not move either the Notebook or the other device during transmission of data. Moving either the Notebook or the other device during transmission distorts the optical signal resulting in loss of data or a system crash.
- An error can occur in FIR transmission if subjected to an environment with high levels of noise. To avoid transmission errors, do not transmit FIR signals near equipment with compressors, such as refrigerators or air conditioners.

## **Multimedia Sound System**

---

The Notebook Computer's built-in audio capabilities allow you to take advantage of a wide range of education and entertainment multimedia software available on today's growing market without the additional costs of add-on cards and peripheral hardware. The multimedia sound system features a sophisticated on-board FM sound generator that produces realistic music and human voice sounds in 16-bit stereo. The integrated speakers are located on the front sides of the Notebook. The internal microphone is located below the LCD display panel to the right of the System Status window. The Notebook is also equipped with both input and output audio ports for external audio units. They are located on the left-hand side of the Notebook next to the AC Adapter port. Please see the illustrations in Chapter 1 if you are having trouble locating any of these components. An external microphone can be connected to the microphone jack. External speakers or headphones can be connected to the Notebook's Headphone-out jack.

All audio features are software controlled. The Master volume is both hardware and software controlled. The audio utility diskette bundled with the Notebook contains several AudioDrive application programs that run under the Windows environment. These applications are compatible with Sound Blaster Pro, and the Microsoft Windows Sound System. With these programs, you can record, store, compress, edit, and playback a variety of sounds and music.

The Notebook's multimedia sound system includes the following features:

- ESS Maestro-2 PCI Audio Accelerator (Sound Blaster Pro™ and Windows Sound System™ compatible)

- A sophisticated on-board 16-bit stereo FM sound generator featuring enhanced stereo and full-duplex playback and record with internal playback and record buffer
- 64-Voice Wavetable Synthesizer
- Secondary CODEC Interface
- AC-3 Speaker Virtualization
- Two integrated speakers and an internal microphone
- Stereo inputs for Line-in, CD-ROM and music synthesis and a mono input for the microphone
- Enhanced Digital Game Port
- Software/Hardware Master Volume Control
- Programmable Power Management
- 5-channel mixer with controls for input and output
- HRTF 3-D Positional Audio under DirectX 5.0
- A 20 Voice FM sound generator capable of the simultaneous voicing of 18 melody sounds and 4 operator-voices via software control
- MIDI serial port compatible with MPU401 UART mode
- I<sup>2</sup>S interface to internal stereo D/A for external ZV port or MPEG audio
- Full PnP support
- Complies with Microsoft ACPI 1.0 and PPMI 1.0 (DO-D3)

## **Audio Volume Control**

---

The Notebook supports the following hot key combinations to control the audio output volume:

[Fn] + [ ]	Increases audio output volume
[Fn] + [ ]	Decreases audio output volume
[Fn] + [F7]	Mutes Stereo Speaker Out sound

This concludes Chapter 3. The next chapter covers attaching peripherals such as a printer or an external monitor.



# CHAPTER 4

## PERIPHERALS

Your Notebook computer is equipped with several ports for connecting a number of peripheral devices such as a printer, a modem, or an external monitor. There are also two PCMCIA Card Bus sockets for connecting industry standard PCMCIA Card Bus cards and stereo jacks for connecting external audio equipment. For added expansion and versatility, you can connect your Notebook to an optional proprietary I/O Replicator (docking station) via the 240-pin connector located on the rear of the Notebook.

This chapter covers the following topics:

- An overview of the peripherals that can be connected to the Notebook
- The necessary requirements for using these peripherals with your Notebook
- Instructions on how to connect these devices to your Notebook

The peripheral devices covered in this chapter are listed below:

- Parallel device
- Serial device
- External monitor
- External keyboard or PS/2 mouse
- PCMCIA interface
- Audio Microphone In, Line-in and Headphone-out
- USB devices
- Phone line to RJ-11 Modem port (optional)
- Television to TV-out port

## Additional Equipment

---

Before attempting to connect a peripheral device to the computer, make sure you are familiar with the Notebook's various I/O ports. Refer to the illustrations in Chapter 1 to identify the following I/O ports. The first six ports in the following list are located on the rear panel of the Notebook.

- An external monitor connector
- One parallel port
- One serial port
- 240-pin docking station connector
- An external keyboard or PS/2 mouse connector
- A USB connector
- Two PCMCIA ports
- An external microphone connector
- An audio Headphone-out connector
- An audio Line-in connector

### External Monitor

The Notebook has a port for connecting an external VGA monitor. The port is a standard 15-pin analog connector commonly used with these monitors. The display output of the computer supports standard VGA color and resolution on a color monitor.

### Parallel Device

This parallel port uses a 25-pin connector, allowing you to attach any equipment that is compatible with this connector standard. This port is most commonly used for connecting a printer. Most printers have a parallel interface. These include dot matrix, ink-jet, and laser printers. The parallel port supports both EPP and ECP capabilities.

***Note!** Your application must be EPP aware to take advantage of the enhanced parallel port's greater throughput. Likewise, your application must be ECP aware to make use of the parallel port's ECP capabilities.*

## Serial Device

This is a standard 9-pin serial port. Any device that uses this standard can be connected to the Notebook. For example, most pointing devices such as a mouse or graphic tablet, can be directly connected to the computer. External modems or fax/modems will usually employ a standard cable. If you have any doubt about the cables required for equipment you plan to purchase, you should consult technical support to ensure you have the correct cables.

## 240-pin Docking Station Port

This port is for the connection of a docking station. A docking station extends the capabilities of the Notebook. The docking station is discussed in Chapter 6 of this manual under the section *Optional Equipment*.

## External Keyboard or PS/2 Mouse

This 6-pinned port allows you to attach a full size enhanced keyboard to the Notebook. You can use any standard desktop computer 101/102-key enhanced keyboard. If you attach an external keyboard and reboot, the computer will automatically detect it. This port also allows you to attach a PS/2 compatible mouse. The PS/2 mouse and the external keyboard share the same auxiliary port. **When using the external keyboard, you will need to make the connection before powering on the Notebook.** This will prevent recognition failure.

## External Mic, Audio Headphone-out and Line-in

There is a built in microphone located just below the LCD screen. You can use it to record voice, sound, and music. There are also three audio jacks, an External Mic, Line-in, and Headphone-out, located under the PCMCIA sockets on the left side of the Notebook. The external microphone jack is used for connecting an external microphone. You can connect external stereo speakers or headphones to the stereo Headphone-out jack. The Line-in jack allows you to connect an output line from stereo equipment such as a tape player to the Notebook.

*The audio jacks are three-terminal stereo jacks. They are not compatible with two-terminal mono plugs. Connecting a mono plug into the Speaker Out jack, may damage the Notebook.*

*The interrupt used is IRQ 5, the DMA is 1, and the I/O address is 220.*

## USB Devices

The Notebook is equipped with a Universal Serial Bus (USB) connector. USB devices are PnP compliant as defined by the Universal Serial Bus

Specification 1.0. Any device that complies with this standard can be connected to this port.

### **RJ-11 Modem port (optional)**

To use the Notebooks modem you must first connect a phone line to the RJ-11 connector.

### **TV Display**

The Notebook's video signal can be converted to a standard video signal and displayed on a TV for viewing or recording to video tape.

## **Connecting Peripheral Devices**

---

### **Connecting An External Monitor**

Please refer to *Figure 4-1* and the following instructions for an external monitor connection:

1. Make sure the Notebook and the monitor are powered off.
2. Ensure that the monitor is the correct type. Do not use a monitor that does not match the VGA standard.
3. Connect the monitor cable to the monitor before connecting the cable to the Notebook's VGA port.
4. Connect the monitor to a power source.
5. Turn on the computer. Turn on the monitor.

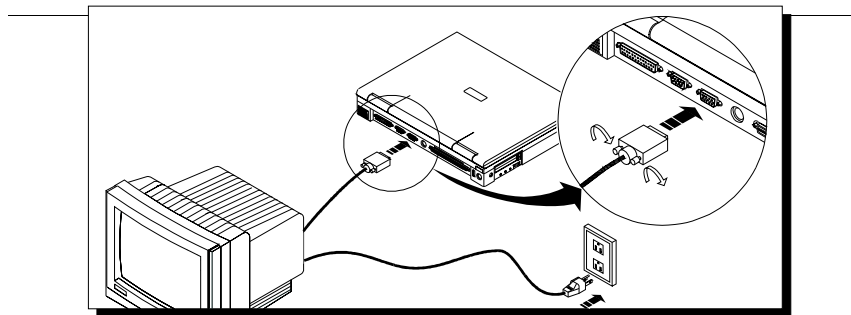
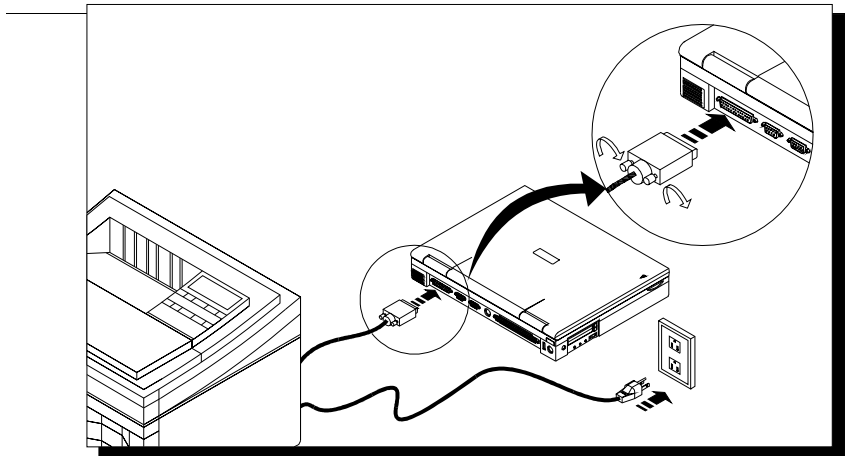

**Figure 4-1: Connecting an External Monitor to the Notebook's VGA Port**

To activate the external monitor you will need to press the hot key combination. Press [Fn] + [F5] on the Notebook's keyboard to toggle between the Notebook's LCD display, simul-scan (simultaneously viewing the Notebook's LCD and external monitor screen) and an external monitor. The Notebook's display panel will be turned off and the external monitor will become the active display.

## Connecting Parallel Devices

To connect a parallel device to the computer you will need the standard parallel 25-pinned connector cable mentioned earlier. Before you connect any device, check the documentation that came with the equipment to see if you need to make any settings or adjustments to the equipment before using it. This might include setting switches to configure the equipment so that it will operate properly with the Notebook and the software you plan to use. Once the equipment is ready, all you will probably need to do is attach the connecting cable. Please refer to **Figure 4-2**.



**Figure 4-2:** *Connecting a Printer to the Notebook's Parallel Port*

**Note!** When using a printer device, it is recommended that you turn on the Notebook first before turning on the printer.

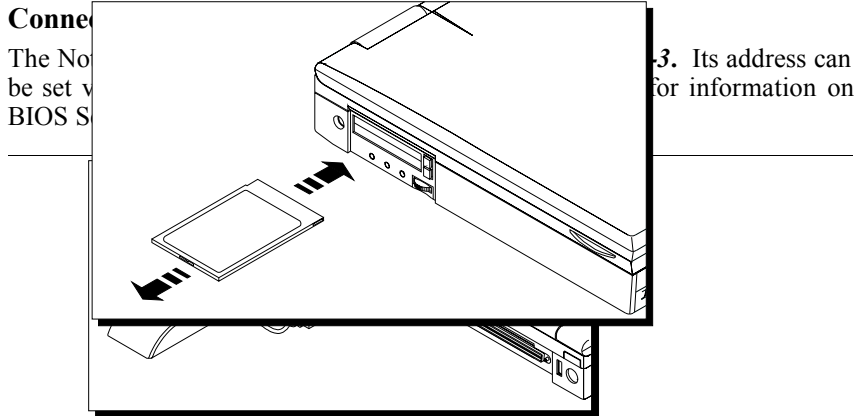

*Figure 4-3: Connecting a Mouse to the Notebook's Serial Port*

### Connecting An External Keyboard

The Notebook has a connection for a full-size enhanced 101/102-key keyboard commonly used with desktop computers. A PS/2 mouse can also be connected to the same port. The external keyboard needs to be equipped with a PS/2 connector. You should be able to obtain a keyboard adapter from your dealer if your external keyboard is not equipped with a PS/2 connector.

To connect a keyboard, perform the following steps:

1. Make sure the computer is turned off.
2. If the keyboard has a PS/2 type connector, plug it into the Notebook's keyboard connector port. If the keyboard has a PC-type jack, connect it to the adapter cable and then plug the other end of the adapter cable into the computer.

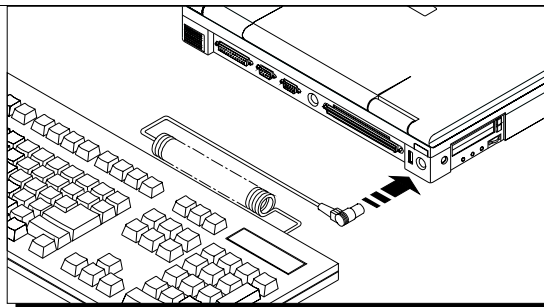

*Figure 4-4: Connecting an External Keyboard to the Notebook's PS/2 Port*

## **PCMCIA Card Bus Cards and Expansion Sockets**

Your Notebook computer features two PCMCIA expansion sockets designed to interface with two Type II cards or one Type III card. This sophisticated innovation allows you to expand and customize your Notebook computer to meet a wide range of computing needs without sacrificing portability. PC cards accommodate a number of expansion options. Memory cards, modems, hard disks, and network (LAN) adapters are just a small sample of the PC card products available on today's market.

### **Inserting and Ejecting PCMCIA Cards**

The PCMCIA (Personal Computer Memory Card International Association) Card Bus is a widely accepted industry standard that defines the design and operation of PC Card Bus cards. PC cards that conform to the PCMCIA standard are plug-and-play devices, i.e., they can be inserted into the PCMCIA expansion sockets while the computer is powered on. This type of hot insertion does not apply to all PC cards. Refer to the documentation that came with your PC card for detailed information on insertion and operation of PC cards.

Please refer to **Figure 4-5** and the following instructions for inserting and ejecting a PCMCIA card:

1. Some PCMCIA cards do not support hot-plugging. Refer to your PCMCIA card's manual for verification. If hot-plugging is not supported, save your data and turn off the Notebook before inserting the PCMCIA card.
2. Hold the PCMCIA card with the arrow side up and the connector side toward the socket.
3. Align the card connectors with the appropriate socket and carefully slide the card into the socket until it locks into place.
4. Locate the two PCMCIA eject switches. Note that there are two eject buttons, one per slot.
5. To remove a PC card simply push the respective eject button once; the eject button pops out. Push the button again to eject the PC card. The upper switch will eject a Type I or Type II PCMCIA card from the upper socket. The lower switch will eject a Type I, Type II, or Type III card from the lower socket.
6. Remove the card and store it properly.

---

***Figure 4-5: Inserting and Ejecting a PCMCIA Card***

*Note!*  
When inserting a Type III PC card, make sure the card is inserted in the lower socket. Before ejecting a PC card, ensure that it is not being accessed by the system. Memory card users must never change a card's write protect switch while the card is inserted into a PCMCIA socket. For example, if the DOS message "Write protect error writing Drive x" is displayed, the user has to change the write protect switch setting on the memory card. To change the switch setting, (a) eject the card, (b) change the switch setting, and (c) re-insert the card.

### **Zoomed Video Port**

As part of the Notebook's advanced architecture, the Zoomed Video port (ZV port) feature provides you with hardware MPEG support. This feature allows you to insert a ZV Port-compliant MPEG PC Card into one of the Notebook's PCMCIA expansion sockets. The ZV port is an extension to the PC Card (PCMCIA) standard that provides a high transfer rate for your computer's video applications. The ZV port achieves this performance enhancement by routing video data directly to the display controller, bypassing the CPU and system bus. This allows for full-screen, full-motion playback of digital video.

*To take advantage of this feature, your MPEG PC Card must be ZV Port-compliant. For installation instructions and details on how to use a ZV Port-compliant MPEG PC Card, refer to the user's manual that comes with the PC Card. Before you can use an MPEG PC Card you must disable the internal MPEG II Card in the BIOS Setup program. See the section "Internal MPEG II" on page 27.*

### **Connecting a USB Device**

The Notebook is equipped with a Universal Serial Bus (USB) connector. The USB connector and its supporting circuitry were designed in full compliance with the Universal Serial Bus Specification 1.0. Any device that uses this standard can be connected to this port. These devices are PnP compliant.

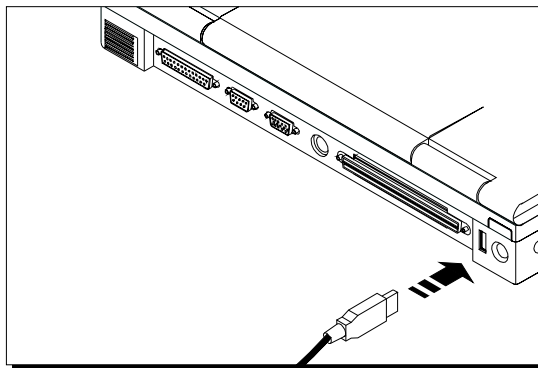

*Figure 4-6: Connecting a USB Device*

### **Connecting a Phone Line to the RJ-11 Modem port (optional)**

To use the Notebook's modem you must first connect a phone line to the RJ-11 connector. The Fax/Modem port is located on the right side of the Notebook (see *Figure 1-1*). To connect a phone line to the Fax/Modem Line connector, follow the instructions listed below:

1. Connect the phone line to the Fax/Modem Line connector. You should test the line first with a telephone to make sure you hear a dial tone.
2. Now install the Fax/Modem device driver to activate the Fax/Modem Module. The Fax/Modem device driver is located on the Fax/Modem Driver Windows 95 Utility Diskette. Refer to the README file on the utility diskette for instructions on installing this driver.

### **Connecting a TV Display to the TV-out Port**

The Composite TV-out port is located on the rear side of the Notebook (see **Figure 1-6**). To connect a television set to the TV-out port, follow the instructions listed below:

1. Turn off the computer.
2. Connect the video in/out cable to the Notebook TV-out port; then connect the other end to the video input of your television.
3. Now power on both the Notebook and the television.

This concludes Chapter 4. The next chapter covers matters related to the Notebook's power system.

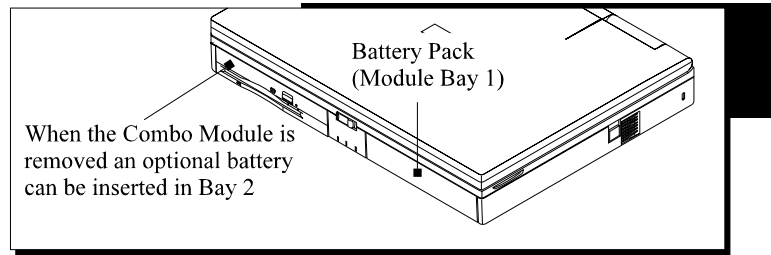

## THE POWER SYSTEM

This chapter contains information on the Notebook's power system, including the AC Adapter, the battery system, recharging the battery, and tips for conserving battery power. Also included is a detailed description of power management and each of the power modes.

The power system is comprised of two parts, the AC Adapter and the battery system. The AC Adapter converts AC power from a wall outlet to the DC power required by the computer. There is one pack inserted in the battery housing at the side of the computer, or otherwise called, Bay 1.

This section covers AC and battery power operation and also explains the software power saving features that are built into the computer.

## The AC Adapter

---

The AC Adapter's primary function is to provide power to the computer. Refer to Chapter 1 for instructions on how to connect the AC Adapter to the computer. When the Adapter is connected to the computer, it provides power as long as it is plugged into an electrical outlet.

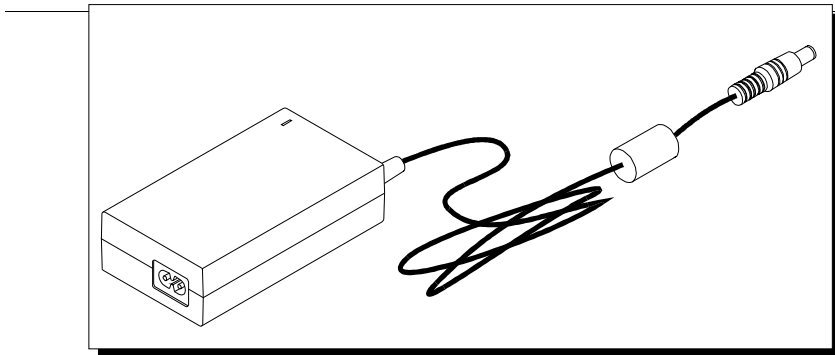

**Figure 5-1: The Notebook's AC Power Adapter**

The Adapter has a built-in indicator light that turns on when you plug the Adapter into a power source. If this light does not come on, the Adapter may not be properly connected, or may not be functioning properly. If the Adapter is not functioning properly, please consult your dealer immediately for support.

## The Battery Power System

---

The Notebook's removable battery pack is found in the battery compartment Bay 1. Please see **Figure 1-1** if you are having trouble locating this bay.

*Note!* A new battery pack should be fully discharged and recharged three times before being used.

A fully charged pack will provide approximately 3 hours of battery life before you have to recharge or replace the battery. Additional battery packs are optional pieces of equipment and can be purchased separately.

Before using the computer on battery power for the first time, check the battery status icon in the System Window display panel to make sure the battery is fully charged. See the section in this chapter labeled *Battery Life Status* for a description and explanation of the different battery icons.

**Figure**

Charging  
or 3 hours  
complete

A safety  
reached  
occurring

There is  
by using  
exceeds  
When the  
charging

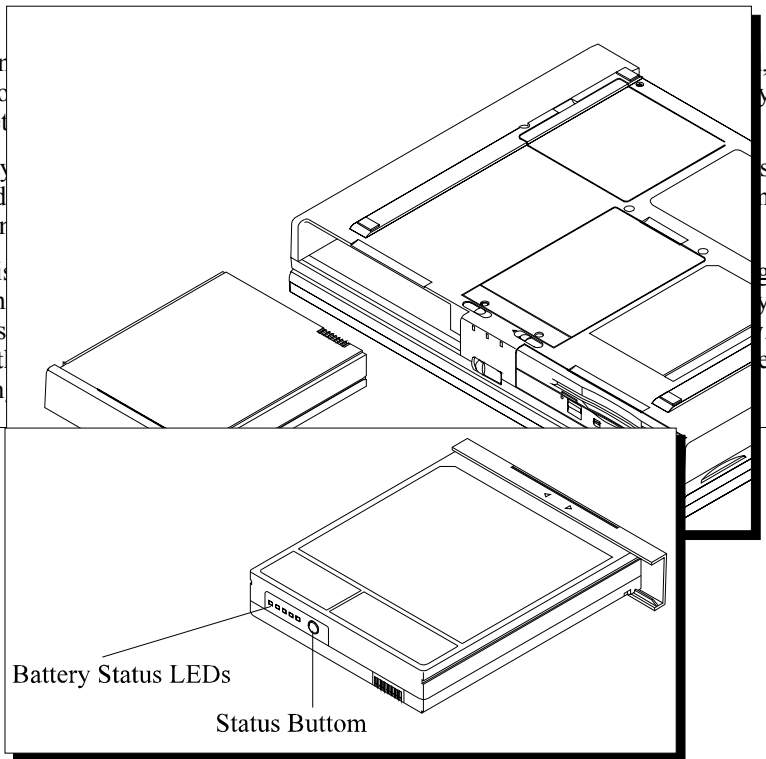

**Figure 5-3: The Main Battery Module**

Notice on the rear of the battery casing there are 5 LEDs and a status button. Please refer to **Figure 5-3**. These LEDs indicate how much battery life is remaining. Press the status button to check the battery's charge. If all five LEDs light, the battery is charged to full capacity. Each LED represents approximately 20% battery charge. There is 80% battery life remaining if four LEDs are lit. If no LEDs are lit, the battery is fully discharged.

## Removing the Battery Pack

To remove the battery pack from its housing, refer to **Figure 5-4** and the following instructions:

1. Turn off the Notebook's power. Never remove a battery module while the Notebook is on.
2. Close the Notebook's cover, ensuring that it snaps into place. Turn the Notebook so the bottom is facing you.

3. Slide the latch lock in the direction of the arrow (1), as shown in **Figure 5-4**.
4. Now, gently pull the module out of its housing (2). The release latch is spring-loaded and will snap back into place when you release it.

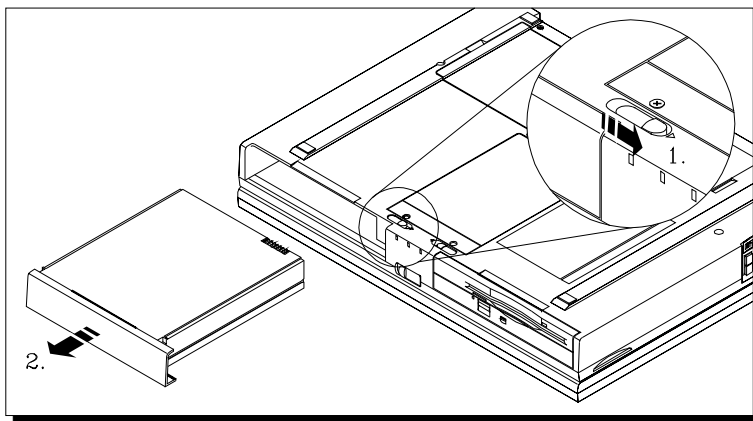

**Figure 5-4: Removing the Battery Pack**

## **Inserting the Battery Pack**

To insert the battery pack into the Notebook refer to **Figure 5-5** and the following instructions:

1. The battery slides into the battery bay as shown in **Figure 5-5**.

Slide the battery into the bay.

has been properly seated, you should hear it click into place. The release latch is spring-loaded and will snap

## **Automatic Battery Pack Charging Function**

There are two ways to charge a battery pack. One is by the aid of the AC Adapter, and the other is by using the optional Battery Pack Charger. This chapter will focus on recharging the battery using the AC Adapter. Recharging the battery by way of the external battery charger is covered in Chapter 6.

When running the Notebook on AC power, the inserted battery pack will automatically be recharged while you are working on your Notebook. There are two charge speeds. When the

computer is turned off or in suspend mode, the charge time is about 2 hours. Otherwise, the charge time is approximately 3 hours.

When the AC Adapter is plugged in, the main battery will always be the first to receive a charge. After being charged to capacity, the secondary battery, assuming it is installed, will then be charged.

If the Notebook is not being charged by AC power, the secondary battery, assuming one is installed, will be the first battery to be discharged. After the secondary battery runs down, the system will begin using the main battery.

If an over 60°C temperature condition occurs while charging the main battery, the process will be stopped. The system will then search for a secondary battery pack, and if located, will begin to charge it. Once the secondary battery charging process commences, even if the main battery temperature falls below 50°C, the system will not switch to charging the main battery until the secondary battery is completely charged.

## AC Power Connection

---

The Notebook can be powered by AC current by connecting the AC Adapter to the external AC port on the Notebook. When the Notebook is operating on AC power, the battery or batteries installed in the Notebook will be charged simultaneously. Please refer to the previous section for information about automatic battery charging. To make an external AC connection, please refer to the following instructions:

---

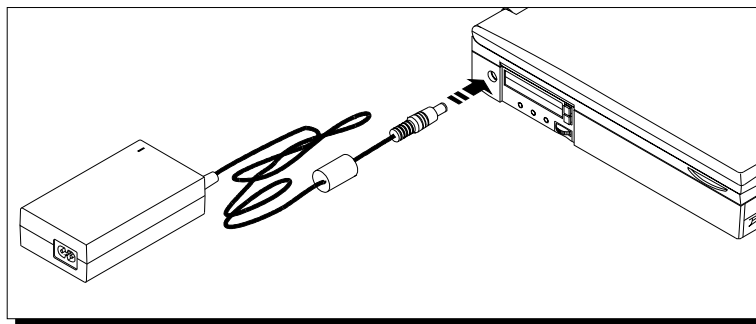

**Figure 5-6: Connecting the AC Adapter to the Notebook's AC port**

1. Insert the end of the AC Adapter output cable into the Notebook's AC port. Please refer to **Figure 5-6**.

Connect the power cable to the port on the AC Adapter module. Please refer to **Figure 5-7**.

Plug the AC Adapter into its power source and press the power On/Off button. If the Notebook does not power up, check the power source, the wall outlet, the AC Adapter and the Notebook. If the Notebook still does not power up, please refer to **Chapter 5 Troubleshooting**.

After work and close all open applications, click on **Start**, then **Shut Down**. In the **Shut Down Windows** dialog box, click **Shut Down** and click **Yes**.

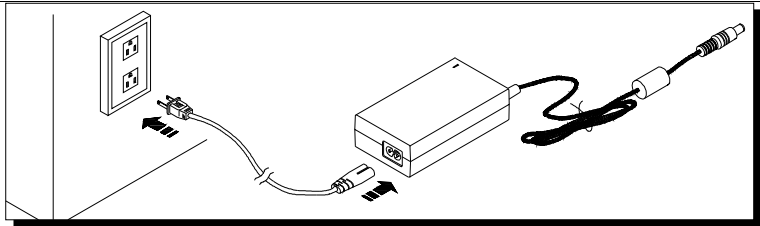

*Note!* The best power source that you can connect any computer device to is a UPS (uninterruptable power supply). A UPS protects your system against electrical surges as well as protecting your data during a sudden loss of power. Your Notebook dealer will be able to provide you with specifics as far as the price and performance of different UPS brands.

## Using Battery Power

---

The battery system will provide approximately 3 hours of power to the Notebook when Power Management is disabled. This figure will vary depending on how you use the power saving features, your general work habits, and the type of CPU and LCD that your Notebook has. We recommend you use the AC Adapter as often as possible to conserve battery power.

The System Window will indicate the status of the battery pack when you are using battery power.

## Battery Life Status

---

Please refer to the sections of the system status window in Chapter 3 for a complete description of each battery icon.

## Low Battery Activity

---

When the battery has entered the critical battery state, the system will begin to beep, prompting you to save your data. Failure to save at this time may result in data loss.

To extend battery power, we recommend you make full use of the Notebook's built-in power saving features discussed later in this chapter.

Use the [Fn] + [F7] hot key combination to turn off the system beep.

## Small Battery for Real Time Clock

---

There is a small built-in battery pack that supplies power to the system in order to maintain certain system information while the power is off.

*Never remove the battery pack while the power is on as this may result in data loss when the system loses power.*

## Power Management Habits

---

While operating the Notebook on battery power, it is important to develop good power saving habits to maximize battery life. Although the Notebook provides automatic power saving features that can be enabled, you can still improve on them by keeping power conservation in mind.

### **The AC Adapter**

The most obvious way to conserve battery power is to avoid using the battery when there is an available AC power source. The AC Adapter is lightweight and compact, so it is very convenient to bring while traveling. By using the AC Adapter as much as possible, you can ensure you will have a charged battery whenever you really need it.

### **The Suspend/Resume Feature**

The Suspend/Resume is one of the Notebook's most useful non-automatic features. If you need to temporarily step away from the computer, simply press one of the two hot key combinations to put the computer into its maximum power saving mode while maintaining your work.

- |              |   |
|--------------|---|
| [Fn] + [R]   | Pressing these hot keys will cause the system to Suspend to RAM.  |
| [Fn] + [F12] | Pressing these hot keys will cause the system to Suspend to Disk. |

When you return, just press the Power On button to restore the system to the point where you stopped.

### **Screen Brightness**

The brighter the LCD display screen is, the more electricity it requires. Avoid setting the screen brightness level higher than necessary to extend the duration of battery power.

### **The Serial Ports**

The computer has one serial port that draws some power if *Enabled*, even though no serial device is being used with the computer. If you are not using a serial device, you can turn the COM port off by using the BIOS program to conserve battery power. Please see Chapter 2 for information on enabling and disabling the Notebook's ports.

### **The Floppy Disk Drive**

The floppy disk drive consumes a substantial amount of battery power. Use the FDD as little as possible when you are operating the computer on battery power.

## **Power Management Modes**

---

The computer has a number of automatic or adjustable power conservation features, which you can use to maximize the duration of the battery's life. You can control many of these features through the Power Menu in the Setup

(BIOS) program. Refer to Chapter 2 for a detailed description of the BIOS Setup program.

The computer is made up of electronic components, all of which consume electricity to operate. Yet, some components consume much more than others. The power management features are designed to conserve as much electricity as possible by putting these components into a low power consumption mode as often as possible. These low power modes are referred to as Standby Time-out and Suspend Time-out.

### **Standby Time-out Mode**

In this mode, the peripheral components are put in their lowest active states in addition to reducing the CPU speed. These include the hard disk and the screen back light. The Notebook enters Standby Time-out mode when the system remains idle for a specified amount of time. This time value can be set from the Power Menu in the BIOS Setup program.

After the system has entered the Standby Time-out mode, to resume normal operation press any key.

### **Suspend Time-out Mode**

This mode saves power by cutting off the power of the CPU and DMA clocks, suspending the math co-processor, turning the video off, and turning off all controllable peripheral devices. The Notebook enters Suspend Time-out mode when the system remains Standby mode for a specified amount of time. This time value can be set from the Power Menu in the BIOS Setup program.

To resume normal operation, press the Power On button.

The Notebook will Save to RAM or Save to Disk; depending on the settings in the BIOS Setup.

### **The PHDISK Utility**

In order to use the Save to Disk function you must first create a Save to Disk (STD) partition or file on the Notebook's hard disk. The PHDISK utility is used to create this partition. During the Save to Disk operation, the system's state is written to this STD partition. Follow the instructions listed below to create an STD partition or file:

Run the PHDISK utility by typing PHDISK/CREATE/PARTITION or PHDISK/CREATE/FILE at the DOS prompt. The PHDISK utility automatically allocates a sufficient amount of disk space required for the STD partition based on the current system requirements.

The amount of disk space required for the Save to Disk operation and the amount of storage space available on the selected drive are displayed before the space is allocated.

Once the STD partition is created, you must run the MSDOS FDISK utility to partition the remaining space on the hard disk. Refer to the MSDOS user's manual for instructions on how to run the FDISK utility.

After the hard disk has been partitioned, format the hard disk. Refer to the MSDOS user's manual for instructions on how to format the hard disk.

*If you want to create an STD partition, you must run the PHDISK utility before partitioning and formatting the hard disk. As this procedure destroys any data on the hard disk, the STD partition should be created before installing any DOS applications, programs, or other software on the hard disk. If you should later decide to upgrade the Notebook's system memory, you may have to run the PHDISK utility again if the additional memory requires a larger STD partition than the one currently in use.*

### **A Suspend Example**

The Time-out settings for Standby and Suspend Time-out specify the amount of time the system must be inactive before the next power management level is enabled. The example below demonstrates this functionality. If the Standby Time-out is set to 2 minutes, and the Suspend Time-out is set to 5 minutes, then the following power management events take place:

1. After 2 minutes of inactivity, the system enters Standby.
2. After 5 additional minutes in Standby (a total of 7 minutes of inactivity), the system Suspends to RAM or Saves to Disk, depending upon the settings made in the Power Menu of the BIOS Setup program.

After the system has suspended, operation can be returned (resumed) to the point in your application where it was suspended. See “How to Resume” for a complete list of resume conditions.

## **How to Suspend**

The system can be suspended in the following ways:

- System enters Auto Suspend. This is enabled by setting a time out period for the Suspend Timeout field in the Power menu. This time out period is the amount of idle time that the system allows before a Suspend is initiated.
- Press the hot key combination [Fn] + [R] to Suspend to RAM
- Press the hot key combination [Fn] + [F12] to Suspend to Disk
- Automatically activating the Suspend function by closing the lid of the Notebook when an external CRT monitor is not connected to the Notebook.
- The battery reaches a critically low power level.

## **The Chain of Suspend Events**

If the system enters Suspend mode from any of the above options, it enters the best power-saving Suspend mode that is supported by the system. When the system suspends, the following events take place:

- A warning beep sounds
- The Suspend indicator in the System Status window is turned on
- The video screen is turned off
- CPU, DMA clocks, and the math co-processor are powered down
- All controllable peripheral devices are turned off
- All system logic (except for the system wake-up circuitry and battery charger) is turned off
- The DRAM and video memory are saved to the hard disk (Save to Disk only)

If the system is left in Suspend to memory (RAM) mode long enough to consume all battery power, then the Suspend indicator goes out and the current contents of the computer’s memory are lost. The system cannot

resume until the battery is recharged or the Notebook is connected to AC power.

### **How to Resume**

Pressing the Power On/Off button causes the system to resume operation after entering Suspend mode. Resuming returns the system's operation to the point in your application where the suspend was initiated. This does not mean, however, that all devices are powered up. When the system resumes, the following events occur:

- DRAM refresh memory returns the system to the application that was running before the Suspend operation
- The video is turned on
- The COM ports are enabled
- Then, each device is powered on when it is requested for use by the system

## **Controllable Features**

---

The Power menu in the BIOS Setup program allows you to specify the amount of inactivity time that must elapse before power saving features are activated. The interval is set using the BIOS Setup program controls as described in Chapter 2. The available ranges are as follows:

<b>Power Mode</b>	<b>Timeout Values</b>
<i>Standby Time-out</i>	<i>1, 2, 4, 6, 8, 12, 16, minutes</i>
<i>Suspend Time-out</i>	<i>5, 10, 15, 20, 30, 40, 60 minutes</i>

## **Smart CPU Mode**

---

The Notebook's BIOS Setup program allows you to enable the Smart CPU mode. This feature slows down the CPU and saves power during brief periods when the system is not busy. This feature can be enabled under the "Power" menu of the Setup program. Refer to Chapter 2 for details.

## Cover Lid Switch

---

The Notebook's LCD Cover Lid Switch is located to the right of the System Status window. See *Figure 1-4*. If the Notebook is powered on and the lid is closed, the LCD panel will power off and the display will be switched to the CRT monitor connected to the VGA port. If a CRT monitor is not connected to the Notebook, the system will enter suspend mode. Opening the cover will resume the system to full power operation.

*Note!* If the LCD/Lid Switch is depressed for less than two seconds, it will be ignored by the system.

## Reactivating From Power Saving Modes

---

After entering one of the power saving modes, the system will return to normal operation in various ways depending on current system status. All of this is transparent to the user. From the user's point of view, the computer reactivates almost as soon as you start to use it again.

## Power Management Summary

---

The following table summarizes the power-saving features of the Notebook:

Power Mode	How to Enter Mode	How to Reactivate
<i>Standby</i>	<i>Transits automatically after specified timeout</i>	<i>Press any key Modem ring, if the Setup program field for this feature is set to Enabled Touch Pad entry or a PS/2 mouse activity if one is connected</i>
<i>Suspend to RAM</i>	<i>Transits automatically after specified time-out Cover is closed Press [Fn] + [R] hot key</i>	<i>Press the On/Off Power button Modem ring, if the Setup program field for this feature is set to Enabled Resume Time, if the value for the Resume On Time field in the Setup program is set to On</i>
<i>Save to Disk</i>	<i>Transits automatically after specified timeout Critical battery condition Press [Fn] + [F12]</i>	<i>Press the On/Off Power button</i>

## **The APM Interface**

---

In addition to the power saving features built into the resident BIOS System Configuration Utility, your Notebook also supports the Intel-Microsoft Advanced Power Management (APM) version 1.2 (or higher) specification. APM is a cooperative interface that enhances the Notebook's built-in power management features by providing one of the most accurate schemes for detecting true idle. This allows APM implementation to put the CPU in a lower power state with no loss in user performance. If APM is installed and properly configured, and power management is enabled in the Setup program, APM functions in the following manner:

- Takes over power management from the system Setup program
- Constantly monitors all system activity to provide one of the most accurate detection schemes for determining true idle under DOS, Windows, Windows 95 and OS/2
- Accounts for operating system inactivity and power demands
- Accounts for application inactivity and power demands
- Allows application programs, DOS and Setup program to share power management features to ensure more efficient use of power
- Determines when power-saving features should be activated
- Operates transparent to the user (behind the scenes)

While you are running an APM aware application, APM will detect any system inactivity. If APM detects that either the operating system or the application is waiting for input (or is in some other idle state), APM will reduce the CPU to minimum speed. Once high speed is required again, APM will increase the CPU to maximum speed. With APM constantly monitoring all system activity, accounting for the Notebook's power consumption, and controlling all power-saving features, you will realize significant additional power savings.

If power management is disabled in the BIOS Setup program, APM will also be disabled regardless of its settings. Once you have enabled the APM interface, some settings made in the BIOS Setup program may be overridden by APM.

Refer to your DOS or Windows manual for a more thorough explanation of the APM interface and its features.

This concludes this chapter on the Notebook's power system. Chapter 6 provides instructions for inserting memory expansion modules and connecting the Notebook to a proprietary I/O Replicator and Docking Station.

# CHAPTER 6

## EXPANSION OPTIONS

This chapter describes the optional equipment that can be added to the basic Notebook system. We use the term expansion here to signify items that are installed inside the computer rather than standard equipment such as a printer that can be connected to the computer's I/O ports. For example:

- You can add more system memory to improve performance.
- Putting the Notebook on a docking station will expand its versatility, making it a suitable replacement for your Desktop PC.

This section also covers the optional modules that can be inserted in the bay located on the right side of the Notebook.

### **System Memory Expansion**

---

The Notebook is equipped with three SODIMM connectors allowing for a total of 384MB of system memory to be installed. These expansion memory cards can be purchased from your dealer.

#### **Expansion Memory Card Types**

Expansion memory cards are 3.3 volt SDRAM and available in three sizes: 32MB 64MB and 128MB.

## Installing Memory Cards

Your Notebook's computer chips, especially RAM (random access memory), are extremely static-sensitive. Static electricity can permanently damage computer chips. It is therefore important to discharge the static electricity from your body before installing the memory module. Discharge your body's electricity by touching the metal shielding around the connectors on the rear of the Notebook computer. Typical grounds are a radiator or a printer case when your unit is plugged in. If you regularly work on your Notebook, it may be beneficial to purchase an anti-static mat or wrist band. Contact your authorized dealer for details on where anti-static devices can be purchased.

You may find it helpful to refer to *Figure 6-1* while reading the following directions.

1. The memory door is located on the underside of the Notebook. Gently pry the door open with a flat-tipped screwdriver (1) and lift it clear (2) to reveal the memory DIMM (Dual Inline Memory Module) slots.

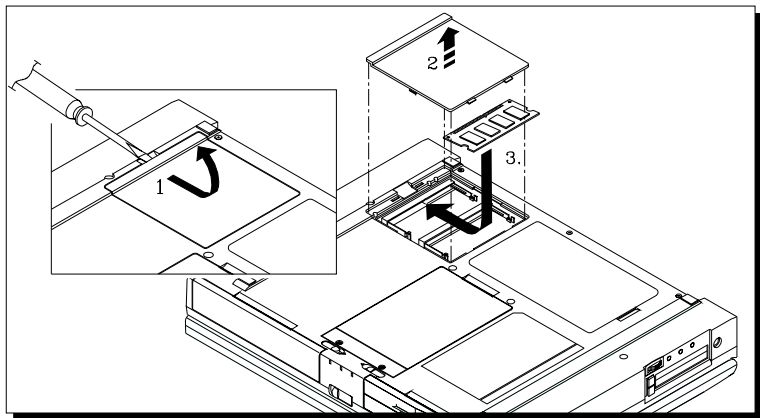

*Figure 6-1: Removing the Memory Door and Installing the Memory Card*

2. After the memory door has been removed, the memory card can be installed. Insert the DIMM at a 45° angle into its slot (3). Gently, but firmly push the DIMM until it locks in place and lies horizontally in its slot.
2. Now replace the memory door in the reverse order in which it was removed.

## Installing and Removing Modules

Your Notebook has the added feature of being capable of supporting three optional hardware modules. The addition of these modules increases your Notebook's versatility and performance.

All modules are installed in the Notebook's Bay 2 port. The battery pack is in Bay 1. Most likely the Combo Module FDD/CD-ROM is in Bay 2. Before you install any of the optional modules, you must remove the Combo Module from the bay. The procedure for removing the Combo Module or removing any of the modules from the bay is essentially the same.

### Removing the Combo Module and Optional Modules

For step by step information on removing any one of the modules from Bay 2 of the Notebook, please refer to the following set of instructions.

1. Ensure that the Notebook is in the power-off mode before removing the Combo module. Failure to do so may cause damage to the electronics of your Notebook or to the module.

Disconnect any peripherals from the Notebook and close its lid.

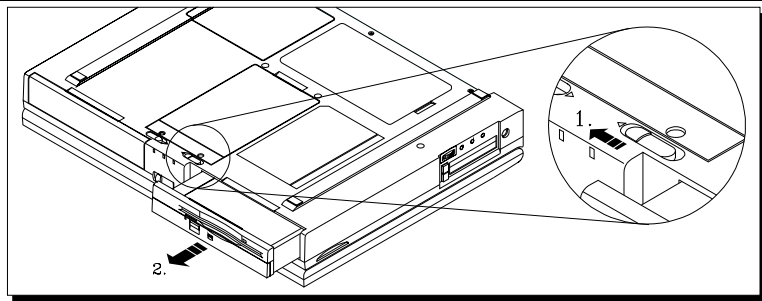

### Removing the Combo Module from Bay 2

Push the Lock/Release latch on the bottom of the Notebook. Please refer to **Figure 6-2**.

Push the Combo Module in the direction of the arrow (1) as shown in **Figure 6-2**. This will unlock the Combo module from the its

connections that follow. The Lock/Release latch is spring-loaded and will snap back into place.

For more information, please refer to the following:

Failure to do so may cause damage to the electronics of your Notebook computer or to the module.

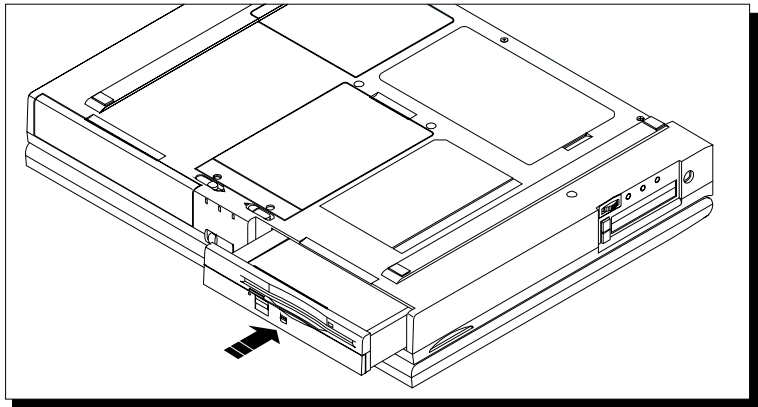

on Removing Modules.  
nap back into place.

## Optional Modules

---

### The Battery Module

The optional battery module allows for extended battery power when you are on the road. The Notebook's battery module will run out of power after approximately 3.0 hours of use. An extra battery module allows you more flexibility in your away from the office schedule, adding an additional 3.0 hours to the computer's operational time.

For information on how to remove the battery from the Notebook in order to replace it with the charged optional module, please see *Figure 5-3* of Chapter 5.

### The CD-ROM Module

This optional piece of equipment provides you with the hardware basics to turn your Notebook computer into a fully functioning multimedia computer. Beyond its audio capabilities, since many software packages are coming out solely on CD-ROM, the addition of this module gives the user more choices in the purchase of software applications.

In recent years, CD-ROMs have become increasingly popular as a mass storage media. One reason is clearly their large storage capacity; CD-ROM disks can hold up to 640 MB of data. And because they are randomly accessible, data can be easily organized for quick retrieval during a search. CD-ROMs can also store a large variety of information, including audio and video data, as well as text files and programs.

### Precautions to Follow when Handling CD-ROM Discs

- Always hold the disc by the edges. Avoid touching the surface of the disc.

Use a clean, dry, cloth to remove dust, smudges, or fingerprints. Wipe from the center outward.

Do not touch the surface of the disc.

Do not use compressed air to clean discs. Store discs in a cool dry place.

**Important!** Do not insert any foreign objects into the disc tray. Do not attempt to open or close the tray manually. When not in use, keep the tray closed to prevent dust or dirt from entering the drive unit. Some CD-ROM drives are equipped with an Audio CD play button. Press this button to play music CDs.

Before using your CD-ROM for the first time, you must install the CD-ROM device driver found on the diskette that came in your CD-ROM optional module package.

### **Installing Device Drivers**

Windows 95/98 automatically installs and configures plug and play hardware devices including your CD-ROM drive. You do not have to install the driver. If you need to reinstall the driver for some reason, please refer to the corresponding driver installation procedure on the Utility diskettes that came bundles with your Notebook.

## **Removing and Installing HDD Modules**

---

Eventually you may find that your Notebook is running out of HDD space. The HDD module provides you with additional hard disk space. The installation of additional HDD modules is relatively simple.

To remove and install HDD modules, please refer to **Figure 6-4**, **Figure 6-5** and the following directions.

1. Turn off the Notebook and disconnect the AC cord and any connected peripherals.
2. Remove the two screws (1) and lift HDD clamp free
3. Slide the HDD in the direction indicated by the arrow (2).

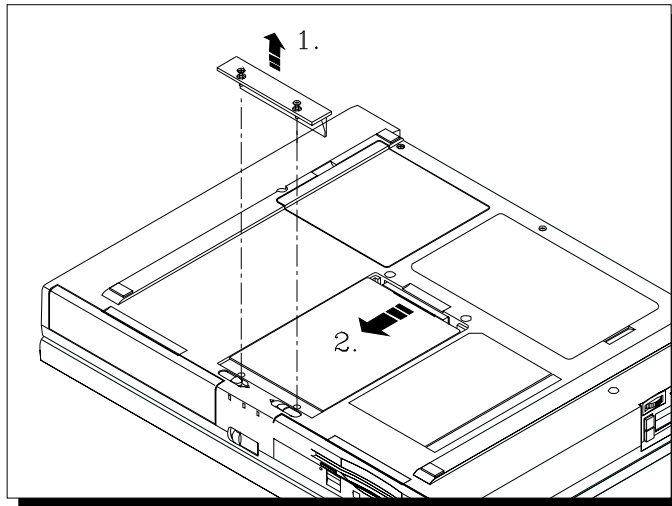

**Figure 6-4: Removing the HDD Module (A)**

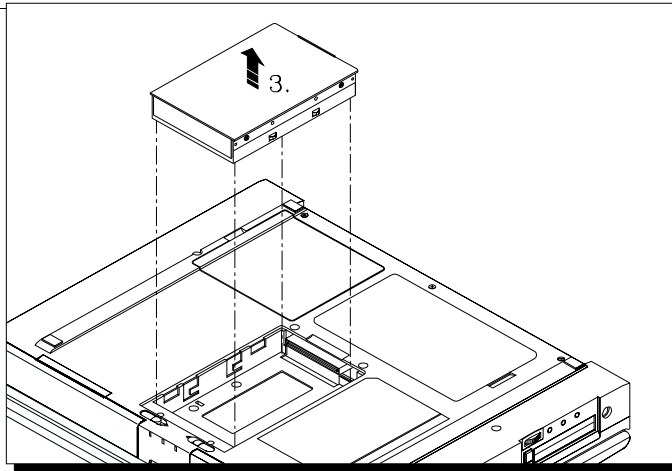

**Figure 6-5: Removing the HDD Module (B)**

4. Lift the HDD out of the bay (3).

Store your HDD module in a safe, dry place away from direct sunlight or heat.

To install the HDD module follow the above instructions in the reverse order and refer to **Figure 6-6** and **Figure 6-7**.

**Removing the HDD module (A)**

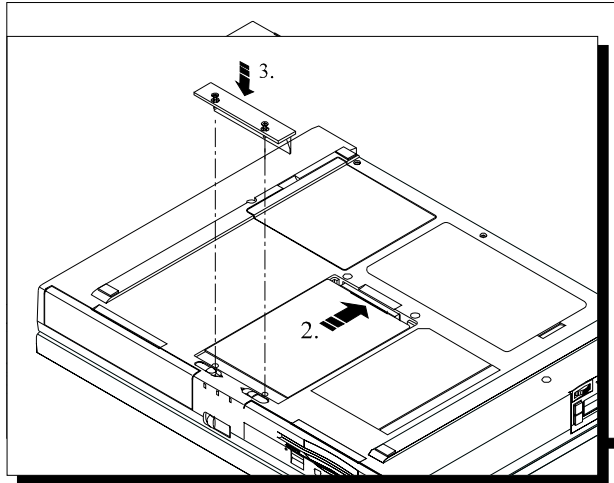

**Installing the HDD module (B)**

## I/O Port Replicator

The I/O Port Replicator features the most innovative advances in Notebook personal computing technology. Much consideration should be given to the design of the I/O Port Replicator in order to meet your requirements for versatility as well as quality.

### Ports and Connectors

To connect your Notebook to any peripheral devices, make sure you are familiar with the I/O Port Replicator's ports and connectors. Please refer to the following diagrams:

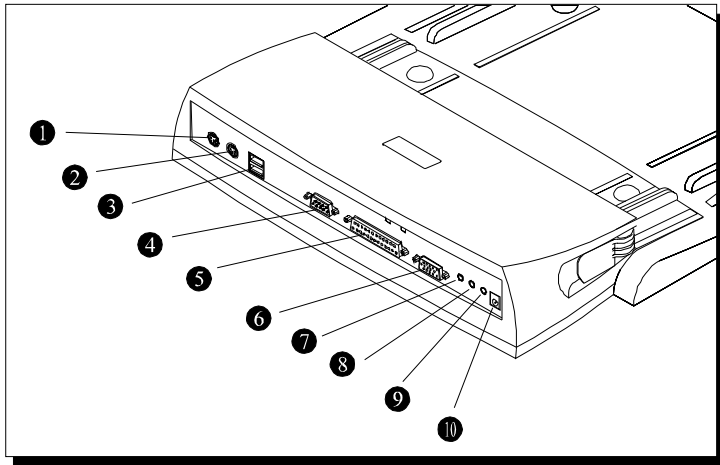

*Replicator's Ports*

in a desk near a wall outlet or an extension cord with a built-in circuit breaker.

your Notebook computer into a fully functional desk-top PC. Your Notebook can be hot-plugged into the I/O

**Warning!** Even though you may be able to fit other Notebook computers into the I/O Port Replicator, it is strongly recommended you do not use it with any other notebooks before checking with an authorized service technician. This could result in severe electrical damage to the Replicator and your Notebook.

To connect your Notebook to the Port Replicator observe the following steps:

1. Prepare the Port Replicator by connecting the desired peripheral devices and connecting the Port Replicator to an AC power source.
2. If no peripheral devices are connected to the Notebook, there is no need to turn off the system since it can be hot-plugged into the Port Replicator. However, it is recommended that you save your data and enter the system into the suspend mode and close the LCD lid.
3. Locate the two grooves on the bottom side of the Notebook. Place the Notebook on the Port Replicator's docking platform, aligning the grooves with the Replicator's docking rails (see **Figure 6-9**).

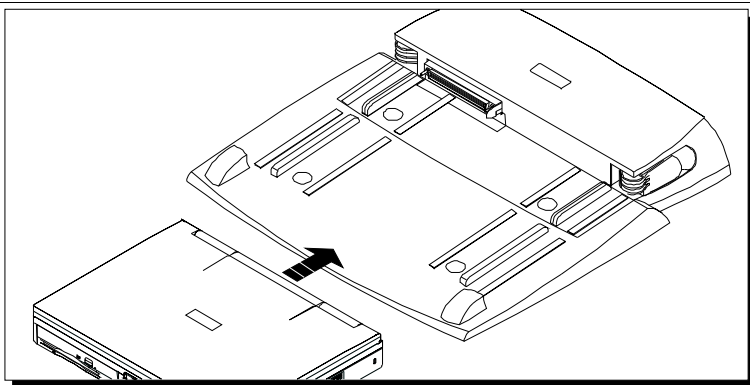

**Figure 6-9: Connecting the Notebook to the I/O Port Replicator**

4. Gently slide the Notebook along the rails of the docking platform until the Notebook's 240-pinned connector makes a connection with the 240-pinned port on the Replicator. If the Notebook does not slide in easily, remove it from the docking platform, realign the grooves to the rails and try again.

Open the Notebook's LCD cover and assuming you entered the system into suspend mode in step 2, resume normal operation.

## Removing the Notebook from the I/O Port Replicator

Refer to the following illustration and instructions to remove the Notebook from the Port Replicator.

1. Save your data and enter your Notebook into the Suspend mode.

Pull both release levers in the direction of the arrows as illustrated in *Figure 6-10*.

Remove the Notebook.

Push the levers back to their original position.

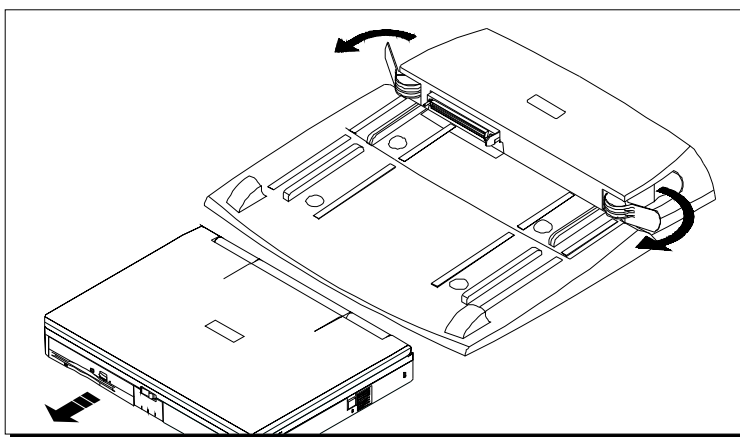

*Figure 6-10: Removing the Notebook from the I/O Replicator*

## I/O Replicator Specifications

### External Interfaces

- One PC/AT compatible parallel port

One PC/AT compatible RS232C serial ports

One monitor connector

One PC/AT compatible keyboard



# CHAPTER 7

## CARING FOR YOUR NOTEBOOK

### General Maintenance

---

The best maintenance you can perform yourself is preventive. Try to keep the computer as clean as possible. Avoid transporting or using it in dirty or dusty environments if possible. Use the carrying bag provided or some other clean container when you transport the computer. Be careful to avoid getting dirt and dust in the floppy disk drive.

Try to keep the keyboard as clean as possible. Avoid spilling liquids on it. You can clean the keyboard with a small computer vacuum to remove dust buildup that can impede key motion. You can occasionally use a vacuum to clean the ports.

Make sure the computer is turned off before unplugging it. When you disconnect cords, remember to pull them by the plugs and not by the cords themselves. This will prevent damage to the cords, plugs, ports, and jacks.

Use a high-quality electrical surge protector, if possible, when your computer is powered by the AC adapter. It is also a good idea to unplug your computer when it is not in use.

## **Cleaning The Computer**

---

### **Cleaning The Case**

If the computer case becomes soiled, you can clean it. Always make sure that the computer is turned off and the AC adapter is disconnected before cleaning the computer. You can clean the case with a soft, preferably lint-free, cloth. If necessary, you can use a mild detergent.

Avoid any cleaner that has abrasives in it and DO NOT use cleaning solvents such as thinner, benzene, or isopropyl alcohol-based products. Never spray anything directly onto the computer. Always spray onto a cloth and then wipe the computer with that. After cleaning, allow 30 minutes drying time.

### **Caring for and Cleaning The LCD Display**

LCD screens are delicate devices that need careful handling. Please pay attention to the following advice:

- When you are not using the computer, keep the LCD screen closed to prevent dust from gathering on the display and on the keyboard.
- Do not put your fingers or sharp objects directly on the surface and never spray cleaner directly onto the display.
- Do not press on, or store any object on the cover when it is closed. It may cause the LCD to break.
- The LCD display panel is covered with glass. You can clean the glass if it gets dirty the same way you would clean a computer monitor screen. Wipe the LCD surface gently with a clean, soft tissue or a lint free cloth and if necessary some commercially available screen or glass cleaner. It is better to avoid ammonia-based cleaners, however. Always spray the cleaner directly onto the cloth; never spray cleaner directly onto the display.

### **Caring for the Touch Pad**

Please pay attention to the following advice when using the Touch Pad:

- Use your finger instead of a pen or other sharp object.
- Ensure that your hands are clean and dry when using the Touch Pad to prevent oil and dirt build-up, which can impair the Touch Pad operation.
- Use one finger only. Touching more than one point on the pad at a time can cause erratic results.
- Finger movement on the Touch Pad should be soft and light. The Touch Pad is not pressure-sensitive and requires very little force.

## **Cleaning the Diskette Drive**

In order to avoid causing damage to the sensitive read/write heads and diskette surface, it is important to prevent dust particles and dirt from entering the disk drive slot. If you suspect that the floppy disk drive needs cleaning, you can purchase a disk drive cleaning kit from your computer dealer. These kits usually consist of cleaning fluid and a diskette case that contains a disk-shaped piece of absorbent material or fabric. Apply a few drops of cleaning fluid to dampen the fabric and then insert the cleaning diskette into the drive. When the drive reads the cleaning diskette, the fabric rotates under the read/write head, removing any dirt or dust particles.

***Note!** Normal usage of these cleaning diskettes is a good way to remove dirt from the floppy drive's read/write head. However when used too often, the fabric can over-abrade the drive head, causing more harm than good. Normal operation of the floppy drive in a dry, dust-free environment is actually an efficient self-cleaning process. Do not use disk drive cleaning kits unless you suspect a problem with the drive. If you have trouble reading a diskette, make sure the problem is not with the diskette itself.*

## **Caring for CD-ROM Discs**

Compact discs are composed of high-density media that must be handled with care and kept clean to ensure that they remain readable. Keep in mind the following to ensure their reliability.

- Always keep your CD enclosed to prevent dust.
- Hold CDs by their edges. Do not touch the surface of the CD.
- Keep the CD surfaces from touching or scraping anything. Do not flex or bend the CD.
- Do not use benzene, thinners, or other cleaners to clean the CD. Use a CD-ROM cleaner kit designed specifically for CDs.
- Do not store or place CDs in direct sunlight.

## Caring for Diskettes

Under normal conditions, a diskette's rigid plastic case will protect it from damage. However, data stored on floppy diskettes are easily corrupted. Follow the protective measures listed below to preserve the integrity of data stored on floppy diskettes.



*Never touch the magnetic surface of the disk.  
When handling diskettes, take care that you do not drop them.*



*Never turn off, reboot, or reset the computer when a diskette is in the drive and the drive activity light is on. Do not transport the computer with diskettes inserted in the drive.*



*Do not expose diskettes to extreme temperatures.*



*Keep diskettes away from magnetic fields generated by power supplies, monitors, magnets, etc.*



*Do not smoke in the same room where diskettes are used or stored. Particles from cigarette smoke are large enough to scratch the surface of the disk. Store diskettes in a dry, dust-free environment.*



*Aside from diskette cleaning fluids, keep all liquids away from diskettes. Never insert a wet diskette into the FDD.*

## Safety Precautions

---

Follow these steps and you will increase the working lifetime of your Notebook. You will also reduce the chance of damage to your computer and personal injury to yourself.

- Follow all cautions and instructions that may be marked on the Notebook.
- Except as described elsewhere in this manual, refer all servicing to qualified personnel. Immediately shut off the Notebook and refer for servicing under the following conditions:
  - when the power cord or plug is damaged or frayed
  - if liquid has been spilled on the Notebook
  - if the Notebook has been dropped or the cabinet has been damaged
- Never push any objects of any kind into cabinet openings. They may touch

dangerous voltage points or short parts that could result in fire or electrical shock.

- Turn off the Notebook before installing or removing a peripheral device.
- Turn off the Notebook and disconnect the AC adapter before cleaning.
- Do not expose the Notebook to direct sunlight.
- Keep the Notebook away from any magnetic devices or TVs.
- Do not use the computer in a dusty or dirty work area. Dust can cause contamination of the unit that can result in malfunction or damage.
- Do not use your computer on an unstable working surface. This will prevent your computer from falling or being knocked over and damaged.
- Keep all liquids away from the Notebook and its accessories.



# APPENDIX A

## TROUBLESHOOTING

Your Notebook has passed through a series of rigorous quality assurance tests to guarantee reliable performance. However, a computer is a sophisticated piece of equipment and as such may malfunction if used incorrectly or if one of its components fails.

This chapter will try to anticipate potential problems that you may encounter in the day-to-day use of your computer. Included are important tips and information you will need to help locate and solve some of the problems you may encounter.

## An Approach to Troubleshooting

In general, troubleshooting involves an organized system of approach to problem solving. Try to isolate the problem and identify the defective device (hardware) or improper setting (software). When you have a problem, you should do a thorough visual inspection of the Notebook. If none of the indicators are lit and you cannot hear the HDD spinning, then the Notebook is probably not receiving power. Make sure the power cord is plugged in, and the AC adapter is securely connected. If you are using a power strip or surge protector, ensure that these devices are turned on.

Often problems are caused by improperly connected cables. If you are using peripherals such as the mouse or keyboard, make sure they are properly connected to their respective ports. Ensure that none of the connectors' pins are bent or broken. Check all cables connected to the Notebook. If any are cut, frayed, or damaged in any way, replace them right away. Never use a damaged cable. A damaged cable is not only a fire hazard, it may also cause a short circuit, resulting in irreparable damage to the Notebook.

This section is organized into categories based on the hardware.

### The Power System

**Question** *When I turn on the computer, nothing happens. What's the matter?*

:

**Answer:** *If your system is running off battery power, the batteries are probably completely drained. Attach the AC adapter and recharge the batteries. If you are running off the adapter, check to make sure that it is plugged into a live power source. If the power indicator light is lit, it indicates that the power source is good and that the adapter is functioning properly. If there is a battery in the computer, turn the power switch off, remove the battery, and then turn on the computer. If there is still no response, consult your dealer for an appraisal of the problem.*

**Question** *The computer keeps beeping at me. Have I done something wrong?*

:

**Answer:** *No, but you may be about to. The computer is most likely trying to tell you that battery power is low. Save your work, quit immediately, and replace the batteries or use the AC adapter as a power source.*

## Booting Up

**Question :** *When I turn the Notebook on, I can't get an operating system prompt to appear on the screen. The Notebook does seem to be running, though.*

**Answer:** *Make sure that you have properly installed an operating system on the hard disk. Check that the brightness and contrast controls are properly adjusted. Try using a system floppy diskette to make sure the operating system will load properly. If it doesn't, contact your support representative.*

## The LCD Display

**Question :** *I know the Notebook is on, but the LCD screen is blank. Is it broken?*

**Answer:** *Probably not. More than likely, the screen contrast or brightness controls are improperly adjusted or you've accidentally put the computer into Suspend Mode by pressing the Suspend/Resume switch. Press the button again to reactivate the screen. Another possibility is that you've turned off the LCD display by pressing [Fn]+[F5] and set the display for an external monitor. Press the space bar first to see if the computer is in Standby Mode. If the screen image doesn't come back, check the contrast and brightness adjustments. If the problem persists, press the [Fn] + [F5] combination to toggle back to LCD mode. If the screen remains blank, consult your dealer for technical support.*

## Keyboard

**Question :** *I can't get the embedded numeric keypad to work.*

**Answer:** *Make sure that the [Nm Lk] key is pressed and the PAD Lock status pattern is on if you want to access the keypad. Conversely, make sure the PAD Lock is off when you want to use the typewriter functions of these keys. Press the [Fn] key to temporarily access the embedded numeric keypad while you hold down the key.*

**Question :** *When I type, I get numbers when I should get letters. What's wrong?*

**Answer:** *The numeric keypad is enabled. Disable it by pressing the [Nm Lk] key. The Num Lock light should go out.*

## I/O Connections

---

### External Monitor

**Question :** *Is it possible to use both an external and the LCD screen at the same time?*

**Answer:** *Yes, the Notebook provides three display configurations: LCD, monitor, and Simul Scan (LCD & MONITOR active at the same time). The three modes are toggled on and off by pressing [Fn] + [F5].*

### Mouse or Other Pointing Device

**Question :** *I connected a Serial mouse to the computer but it doesn't work. Why is this?*

**Answer:** *First, make certain you followed the manufacturer's installation instructions completely to install the mouse properly. If you installed the mouse correctly and it doesn't work, check the following:*

*Make sure the serial port option of the Setup program is set to the same port that is selected for the mouse driver.*

*Set the mouse device driver to the corresponding COM port which is selected for the serial port option.*

# APPENDIX B

## SPECIFICATIONS

### Specifications

#### Intel MMC-2 Board

- Intel MMC-2 P55CLM, Mobile Deschutes
- 512K L2 Cache
- Intel system logic

#### System Memory

- Upgradable to a maximum of 384MB by installing one two or three, 32MB, 64MB, or 128MB additional SODIMM memory modules

#### Fixed (Hard) Disk Drive

- 2.5" (12.7 mm) up to 8GB HDD

#### Floppy Disk Drive

- 3.5" 1.44MB floppy disk drive

#### Display

- 13.3" Color TFT LCD with an 1024 x 768 XGA resolution back-light display  
Dimensions: 318.0mm(W) x 250.5mm(H) x 51.9mm(D)  
with an active area of 270.34mm (W) x 202.75mm (H).
- 14.1" Color TFT LCD with an 1024 x 768 XGA resolution back-light display  
Dimensions: 318.0mm(W) x 250.5mm(H) x 51.9mm(D)  
with an active area of 285.7mm (W) x 214.3mm (H).

#### Keyboard

- 87/88 keys PC/AT compatible keyboard and embedded numeric keypad

and special hot keys.

### **External Interfaces**

- One 9-pin serial port
- One 25-pin parallel port
- One 15-pin CRT Monitor port
- One 6-pin external keyboard port
- One Audio Mic port, one Headphone-out port, and Line-in port
- Built-in microphone
- Built-in FIR transmitter-receiver
- 240-pin Docking Connector supporting a Docking Station and I/O Replicator
- One 2-pin AC adapter jack
- Two 68-pin ACPI-compliant Type II PCMCIA slots
- Two built-in speakers
- One 4-pin USB port
- One TV-Out (S-Type) port
- RJ-11 Modem port (optional)

### **System Window Icons**

- Caps Lock
- Numlock
- Scroll Lock
- Keypad Lock
- FDD activity
- PCMCIA activity
- CD-ROM/HDD activity
- AC power
- Main battery or Secondary battery icon
- Battery power status icon

### **LED**

- Power Status

- HDD Activity
- Battery Status

### **External Controls**

- Power On/Off
- LCD Lid Switch
- Power Kill Button

### **Standard Accessories**

- AC adapter
- Carry bag

### **Battery**

- One Rechargeable Li-Ion battery pack
- 3 operation hours using Li-Ion battery and PMU disabled (May vary depending on operating temperature, battery condition, and power management features.)
- 3 hours fast charge when power is on, 2 hours when off when using Li-Ion battery. (May vary depending on operating temperature, battery condition, and power management features.)

### **Power Management**

- System activity monitor
- Automatic transition between modes (Active/Standby/Suspend)
- Other intelligent power management technology

## Weight

13.3" Color TFT LCD

8.5 lbs./3.85 kg including battery and Combo (FDD/CD-ROM) module

14.1" Color TFT LCD

8.5 lbs./3.85 kg including battery and Combo (FDD/CD-ROM) module

## Optional Equipment

- FDD/CD-ROM, FDD/DVD, LS-120 Drive
- Removable IDE Hard Disk Drive
- 56K V.34 Fax/Modem
- TV Output Adapter
- I/O Replicator
- Extra memory modules (32, 64, 128MB 144-pin 3.3V SODIMM)
- Li-Ion Main/Secondary Battery Pack

 *Specifications are subject to change without notice.*

## Upgrading your Notebook

This Notebook can be upgraded by installing a more efficient CPU, a larger HDD, and more memory modules. This manual guides you in a step-by-step manner through some upgrades and installation procedures. Please refer to the *Table of Contents* to locate the particular section of interest. If after reading this manual, you are not completely confident that you have the ability to perform the upgrading task, please seek assistance from your Notebook dealer. Please contact your dealer for upgrade information.

HD03030I206